

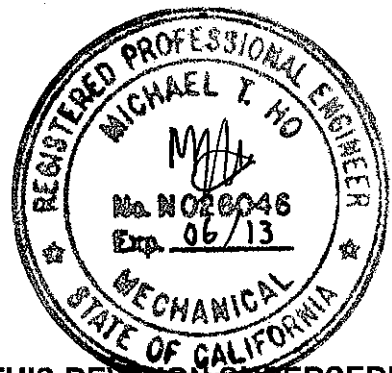

Rolling Doors

SERVICE DOOR INSTALLATION INSTRUCTIONS



THIS REVISION SUPERSEDES
ALL PREVIOUS REVISIONS

FREIGHT DAMAGE INSTRUCTIONS

IMPORTANT

IMMEDIATELY UPON DELIVERY CHECK CONDITION OF MATERIALS FOR VISIBLE CONCEALED FREIGHT DAMAGE INCURRED IN TRANSIT.

UNDER NO CONDITION SHOULD INSTALLATION BE MADE WITHOUT AUTHORIZATION, AS NEITHER THE CARRIER NOR THE MANUFACTURER WILL ASSUME RESPONSIBILITY FOR LABOR COSTS INVOLVED IN REPLACING DAMAGED MATERIAL THAT HAS BEEN INSTALLED.

FOLLOW THE DIRECTIONS BELOW:

CONCEALED DAMAGE:

- (A) MUST BE INSPECTED BY CARRIER'S REPRESENTATIVE WITHIN 15 DAYS FROM DATE OF DELIVERY.
- (B) CONSIGNEE MUST OBTAIN COPY OF INSPECTION REPORT.
- (C) MATERIAL SHOULD NOT BE MOVED FROM POINT OF DELIVERY TO OTHER PREMISES PRIOR TO DISCOVERY AND/OR REPORTING OF DAMAGE.
- (D) CONTAINER AND PACKING SHOULD BE RETAINED BY CONSIGNEE UNTIL INSPECTION IS MADE.

VISIBLE DAMAGE:

- (A) MUST BE INSPECTED BY CARRIER'S REPRESENTATIVE WITHIN 15 DAYS FROM DATE OF DELIVERY.
- (B) CONSIGNEE MUST OBTAIN COPY OF INSPECTION REPORT.
- (C) MATERIAL SHOULD NOT BE MOVED FROM POINT OF DELIVERY TO OTHER PREMISES PRIOR TO DISCOVERY AND/OR REPORTING OF DAMAGE.
- (D) CONTAINER AND PACKING SHOULD BE RETAINED BY CONSIGNEE UNTIL INSPECTION IS MADE.

NOTE: IF DAMAGE IS CERTAIN, GOODS SHOULD NOT BE UNPACKED UNTIL INSPECTION IS MADE. IF DAMAGE IS UNCERTAIN, PACKAGES MAY BE OPENED BUT PACKING MATERIAL MUST BE SAVED UNTIL INSPECTION IS MADE.

INCOMPLETE DELIVERY:

- (A) SHOULD BE NOTED ON DELIVERY RECEIPT.
- (B) ACKNOWLEDGES BY DRIVER'S SIGNATURE.
- (C) START TRACING IMMEDIATELY.
- (D) NOTIFY SHIPPER.

RETURNING DAMAGED MATERIAL:

IF DAMAGED TO THE EXTANT THAT IT IS NECESSARY TO RETURN TO THE MANUFACTURER TO BE REPAIRED, PLEASE DO AS FOLLOWS:

- (A) OBTAIN PERMISSION TO DO SO FROM THE DELIVERING CARRIER.
- (B) ROUTE THE RETURN SHIPMENT VIA THE IDENTICAL CARRIER(S) INVOLVED IN THE ORIGINAL SHIPMENT.
- (C) NOTIFY THE MANUFACTURER WHEN SHIPPED.

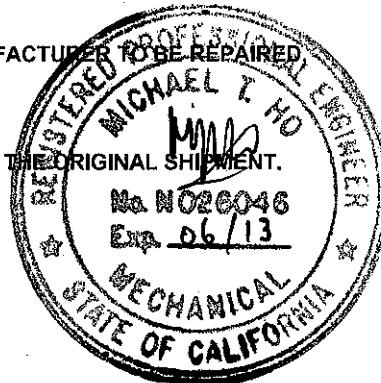

SERVICE DOOR INSTALLATION INSTRUCTIONS

TABLE OF CONTENTS

PAGE#	DESCRIPTION	FIG#
1	Pre-Installation Instructions/Safety Checklist	
2 / 3	Guide Installation	1-6
4	Optional Welded Wall Angle Installation	7
5	Fastener Table	
5	Guide Groove Dimension Table	
6	Barrel & Bracket Assembly	8 / 9
7	Curtain Assembly for SD/FD/or Grille Door	10 / 11
8	Tensioning Instructions- Standard Tension Wheel	12
8	Tensioning Instructions- Special Tension Sprocket	13
9	Hood Support Mounting Instruction	14 / 15
10	Hood Installation	16 / 17
<u>Manual Operators</u>		
11	Hand Chain Operator Installation	18
11	Crank Gearbox Assembly- Worm Gear Type	19
12	Crank Operated Installation Instructions	20
13	Thru-Wall Crank Operated Installation Instructions	21
14	Thru-Wall Chain Operated Assembly	22
<u>Motor Operators</u>		
15	Vertically Mounted Motor Operator	23
16	Vertically Mounted 3 HP GH Double Reduction Bracket	24
17	Horizontally Mounted GH Motor Operator	25
18	Side Mounted GH Motor Operator	
18	Wall Mounted Operator	26
19	Thru Wall GH Motor Operator	27
20	Belt Drive Motor Bracket Assembly- Top Mount	28
21	Instructions for setting Rotary Limit Switch	29
<u>Safety Edges / Devices</u>		
22	Safety Edge Coil Cord / Cord Reel Installation Inside Door W/ Motor Mounted Controller	30
23	Safety Edge Coil Cord / Cord Reel Installation Outside and Above Mounted Doors	31
24	Failsafe Safety Edge Installation Instructions	32
25	Setting Instructions for Featheredge Switch	33
25	Top Safety Limit Switch Installation	34
26	Top & Bottom Safety Limit Switch Installation	
27	Inertia Brake Installation Instructions	
<u>Weather Stripping</u>		
28	SD Guide Weatherstrip Installation Instruction	
29	Guide Weatherstripping	
30	Brush Type Gasketing Installation Instruction	
30	Reverse Hood Baffle Installation Instructions	
31	Florida Doors Optional Welded Wall Angle Installation	

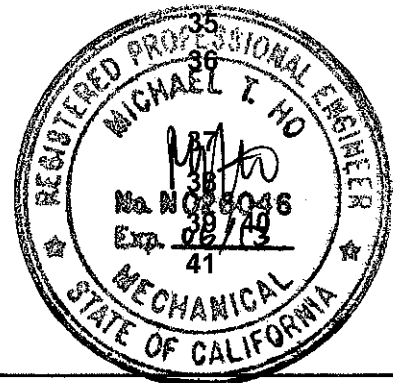

PRE-INSTALLATION INSTRUCTIONS

WARNING



ONLY TRAINED DOOR SYSTEMS TECHNICIANS SHOULD DROP TEST, RESET OR PERFORM MAINTENANCE ON DOORS

WARNING



READ AND FOLLOW THESE INSTRUCTIONS THOROUGHLY - THE MANUFACTURER WILL NOT BE HELD RESPONSIBLE FOR ANY CHARGES INCURRED THROUGH MISSING PARTS, OPERATION, OR DAMAGE - DUE TO IMPROPERLY INSTALLED DOOR ASSEMBLIES

- 1) IF YOU HAVE RECEIVED MORE THAN ONE DOOR, YOU WILL FIND THAT ALL MAJOR PARTS AND PIECES FOR ANY ONE DOOR ARE MARKED WITH CORRESPONDING NUMBERS; THEREFORE, A COMPLETE DOOR SHOULD BE COMPOSED OF PARTS BEARING THE SAME NUMBERS AND LETTERS.

DO NOT INTERCHANGE PARTS FROM ONE DOOR TO ANOTHER!!!

- 2) BEFORE INSTALLING THE DOOR SEE THAT ALL COMPONENT MARKINGS AGREE.
- 3) BEFORE ATTEMPTING INSTALLATION OF THE DOOR AND, SPECIFICALLY, BEFORE LEAVING THE JOBSITE MAKE CERTAIN YOU HAVE READ AND ADHERED TO THE ATTACHED "SAFETY CHECK LIST".
- 4) SHOULD THERE BE ANY DISCREPANCIES IN THE JOB CONDITIONS OR MANUFACTURED MATERIALS, CONTACT THE COOKSON COMPANY, INC. IN WRITING OR BY CALLING 1-800-294-4358 FOR WESTERN U.S. AND CANADA OR 1-800-390-8590 FOR EASTERN U.S. AND CANADA. IF DOOR WAS PURCHASED BY A COOKSON DISTRIBUTOR AND SOLD TO ANOTHER PARTY THEY SHOULD CONTACT THE DISTRIBUTOR FOR WARRANTY OR REPAIR RIGHTS.

SAFETY CHECK LIST

WARNING



IN ORDER FOR YOU TO ASSURE YOUR CUSTOMER THAT THIS DOOR HAS BEEN INSTALLED PROPERLY AND IN A SAFE MANNER, WE ASK THAT YOU CHECK THE FOLLOWING BEFORE LEAVING THE WEBSITE

- 1) MAKE CERTAIN THAT THE PROPER AMOUNT OF TENSION HAS BEEN APPLIED TO THE TORSION SPRINGS, IN ORDER TO PROPERLY COUNTERBALANCE THE WEIGHT OF THE CURTAIN.
- 2) ASSURE YOURSELF THAT THE TENSION WHEEL IS SECURELY FASTENED IN PLACE.
- 3) ASSURE YOURSELF THAT SPROCKETS OR GEARS REQUIRING KEYS HAVE THE CORRECT KEYS INSTALLED AND DRIVE SHAFT SPROCKETS OR GEARS ARE RETAINED BY COTTER PINS.
- 4) RECHECK THE SETSCREWS (ONE OVER KEY - THE OTHER LOCATED AT 90° FROM KEY) ON EACH SPROCKET OR GEAR FOR TIGHTNESS.
- 5) CHECK ALL FASTENERS HOLDING GUIDES TO BUILDING STRUCTURES.
- 6) CHECK ALL FASTENERS USED IN ASSEMBLING DOOR COMPONENTS.
- 7) INSTRUCT OWNERS OR HIS/HER REPRESENTATIVE IN THE PROPER METHOD OF OPERATING THIS DOOR

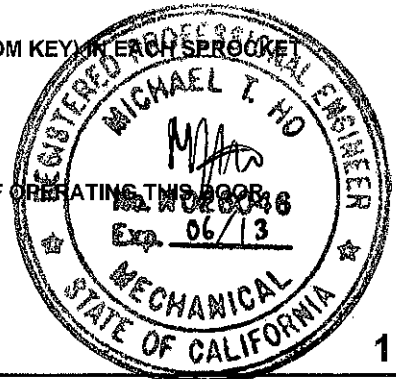

SERVICE DOORS GUIDE INSTALLATION

Depending on your specific job conditions, you have received guides that appear as shown below.

TYPE I ASSY

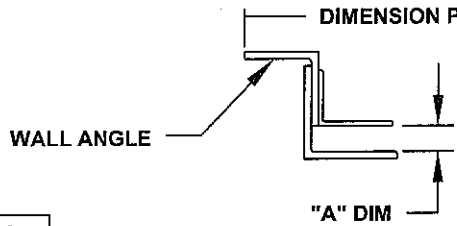

TYPE II ASSY

STANDARD
FACE OF WALL
MOUNTED GUIDE

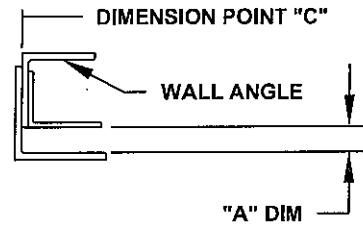

FIG 1

TYPE 6, 8, 9 & 12

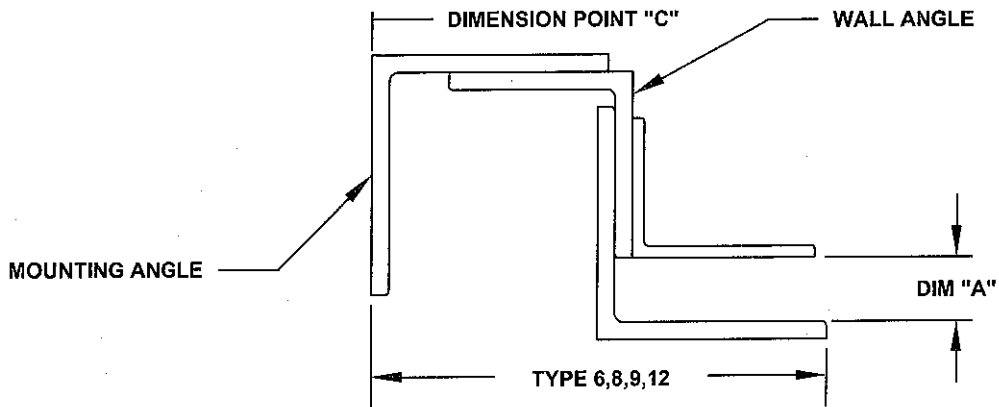

FIG 2

TYPE 3

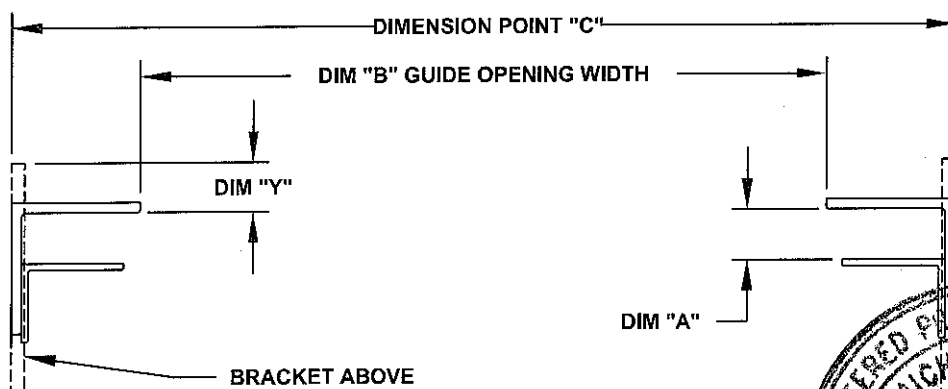
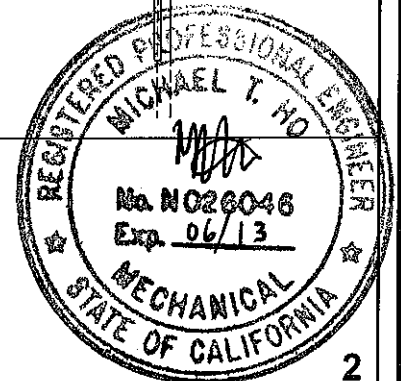

FIG 3



SERVICE DOORS GUIDE INSTALLATION

TYPE 4

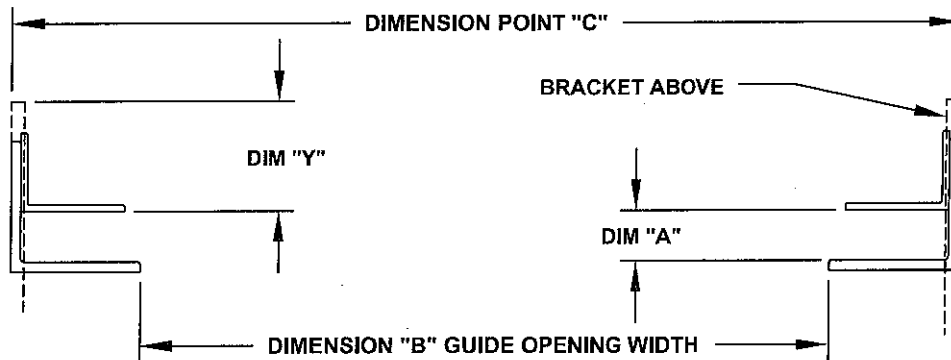

FIG 4

- 1) Locate guide dimension point for both left and right jamb. Measurement between dimension points must equal dimension "C".
- 2) For typical installation for Type I and II (See FIG 1) guide assemblies, Dimension point "C" is centered around jamb opening - (if side room permits) - if there are questions check job construction drawings (if available).
- 3) Check the Guide opening measurement. Locate a mark on the floor at the tip of each guide and measure. Guide measurement must equal Dim "B". (See FIG 6) **THIS IS CRITICAL** If guide opening does not equal Dim "B", **STOP** and redo steps 1 and 2.
- 4) Scribe a plumb line on the wall at dimension points.
- 5) Place the guides against the scribed line and with the tops of guides level, mark the location of the mounting holes. NOTE: Guide types 2, 6, 8, 9 & 12 may have to be disassembled
- 6) Drill mounting holes for wall fasteners and mount the guides. (See Page 4 for fastener type) Reassemble guides if necessary.
- 7) Make sure that the width of the guide groove is equal to Dim "A". (See Page 4) Adjust if necessary.

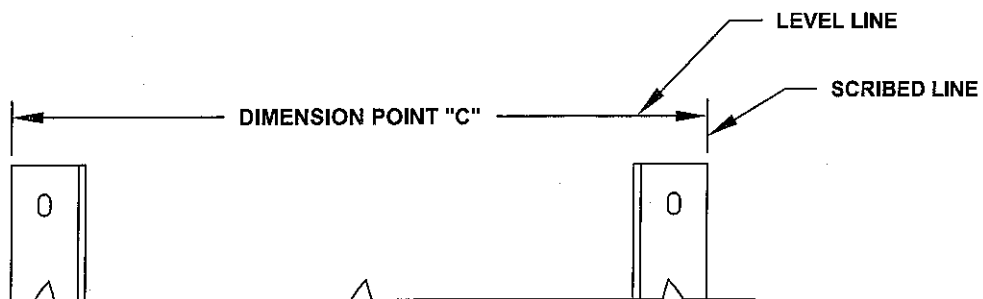

FIG 5

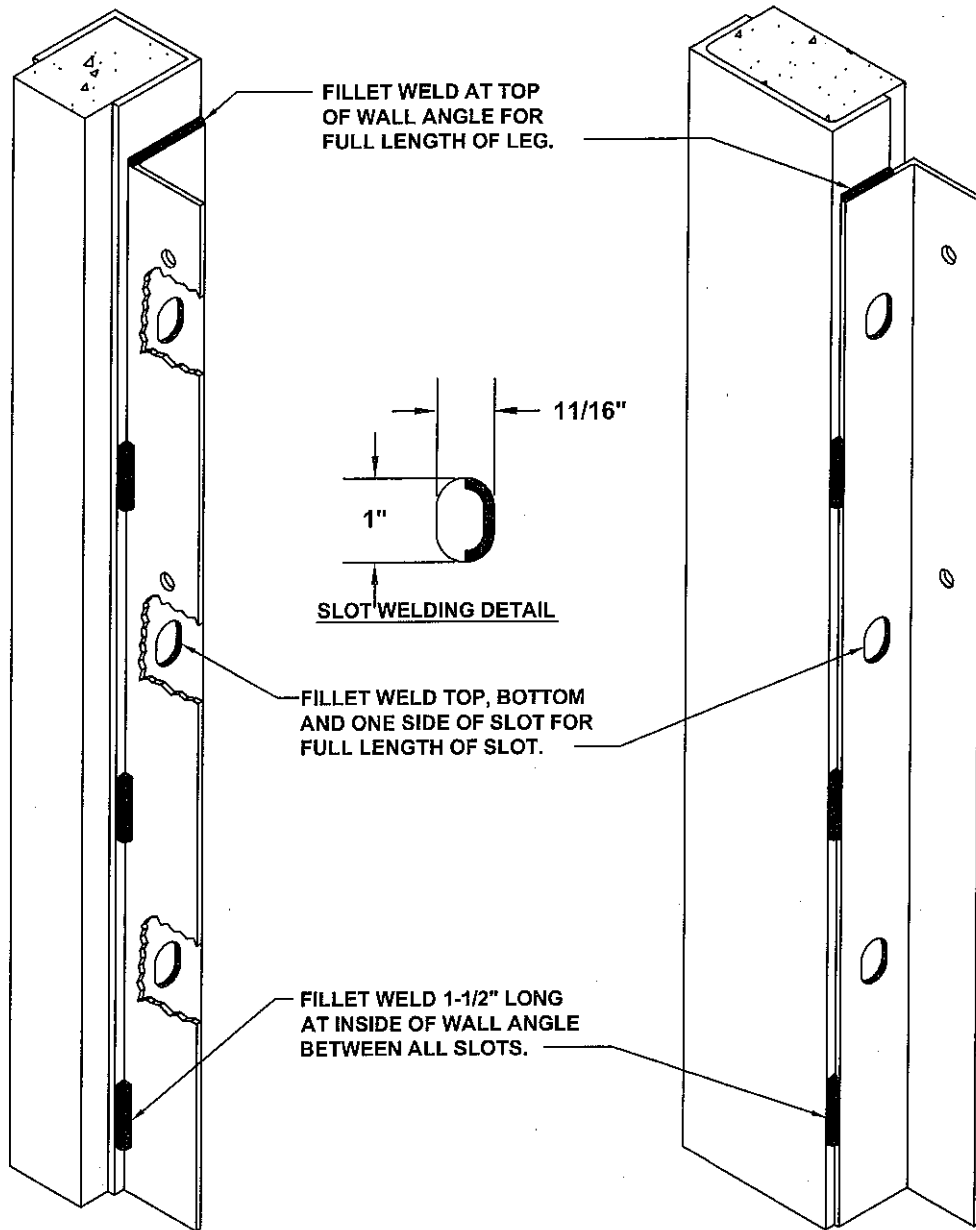

FIG 6



OPTIONAL WELDED WALL ANGLE INSTALLATION APPVD FOR WARNOCK HERSEY AND UL LABELED DOORS

NOTE: APPROVED FOR STRUCTURAL STEEL JAMBS ONLY.



METHOD 2

(WELDING ON INSIDE OF WALL ANGLE)

METHOD 1

(WELDING ON OUTSIDE OF WALL ANGLE)

FIG 7

FILLET WELD SIZES ARE TO BE EQUAL TO THE WALL ANGLE THICKNESS.

(FILLET WELDS TO BE MINIMUM 3/16" WIDE).

USE E6011/E6011 ELECTRODES OR ELECTRODES OF EQUIVALENT STRENGTH.

ALL WELDS TO BE DONE "VERTICAL-UP" (START FROM THE BASE OF AN INDIVIDUAL WELD AND WELD UPWARDS)

WELDING PROVISIONS TO BE IN COMPLIANCE WITH U.B.C. STD #27-6.

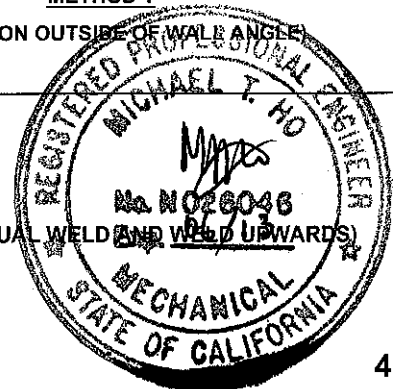

FASTENER TABLE

NOTE: If doors are windload tested / certified refer to specific approval documentation for required mounting conditions/fasteners.

TYPE OF CONSTRUCTION TO WHICH FASTENER EMBEDS	TYPE OF FASTENER TO USE	HOLE SIZE (DRILL DIA.)	TAP SIZE (IF REQ'D)	DEPTH OF HOLE
WOOD	Ø1/2" X 3" LAG BOLT	Ø5/16"	_____	2-1/2" MAX
	Ø5/8" X 3-1/2" LAG BOLT	Ø7/16"	_____	3" MAX
CONCRETE WIDE WALL	Ø1/2" X 5-1/2" WEDGE ANCH.	Ø1/2" CARBIDE	_____	4" MIN
	Ø5/8" X 6" WEDGE ANCH.	Ø5/8" CARBIDE	_____	5" MIN
	Ø3/4" X 8-1/2" WEDGE ANCH.	Ø3/4" CARBIDE	_____	6" MIN
MASONRY OR BRICK WIDE WALL	Ø5/8" X 4-1/4" SLEEVE ANCH. (Ø1/2" BOLT)	Ø5/8"	_____	4" MIN
	Ø3/4" X 6-1/4" SLEEVE ANCH. (Ø5/8" BOLT)	Ø5/8"	_____	5" MIN
STEEL	Ø1/2" BOLT	Ø27/64"	1/2"-13UNC	_____
	Ø5/8" BOLT	Ø17/32"	5/8"-11UNC	_____
	Ø3/4" BOLT	Ø21/32"	3/4"-10UNC	_____

NOTE: See page 4 if the guides are to be welded to the jambs.

NOTE: See page 31 for mounting of Florida Approved Doors.

GUIDE GROOVE DIMENSION TABLE

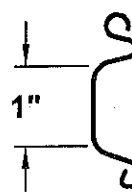
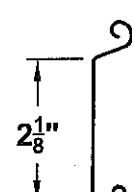
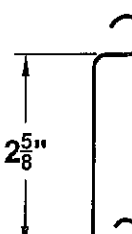
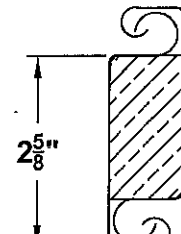
SLAT NO.	1	5	4	44 DBL.INSUL
SLAT PROFILE				
DIM "A"	1"	1"	1 1/8"	1 1/4"

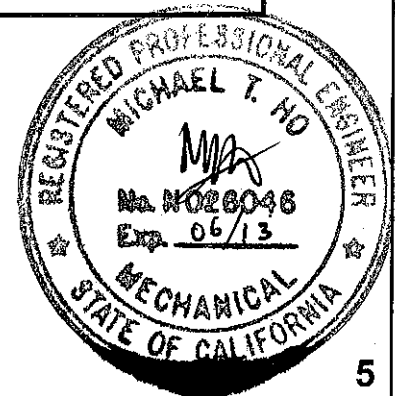

BARREL AND BRACKET ASSEMBLY

- 1) Determine whether you have Right Hand (RH) or Left Hand (LH) drive, place the barrel below the opening in the position it takes when actually mounted. If you have hoops or wire rings consult FIG 8.

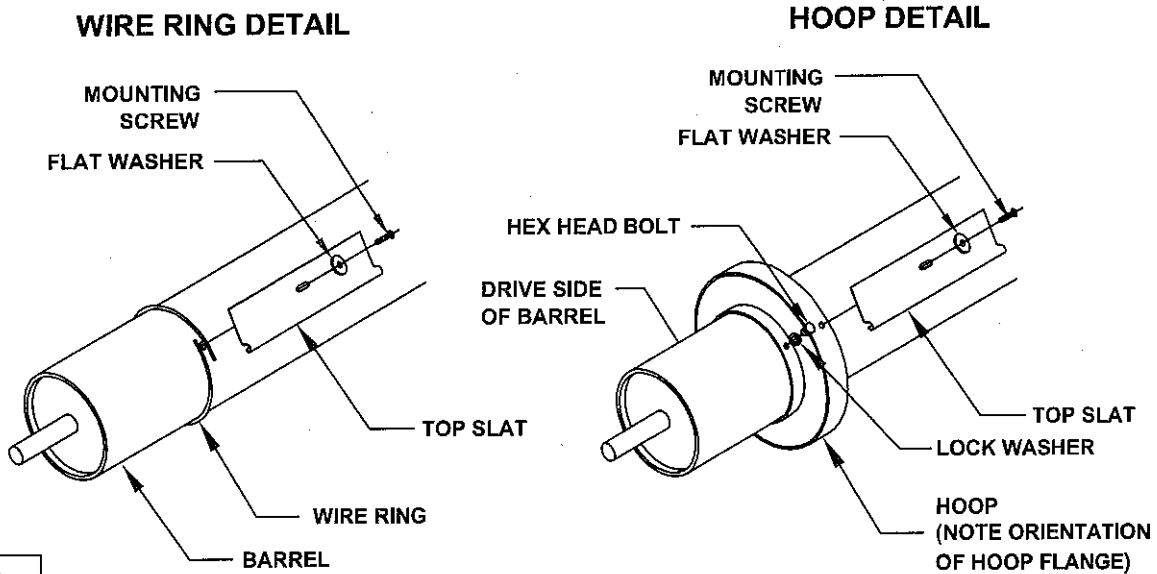

FIG 8

- 2) Slide the mounting brackets onto their respective ends of the barrel and raise the entire assembly into position at the head of the opening.
- 3) Using the carriage bolts as shown in FIG 9, bolt the brackets to the wall angle.

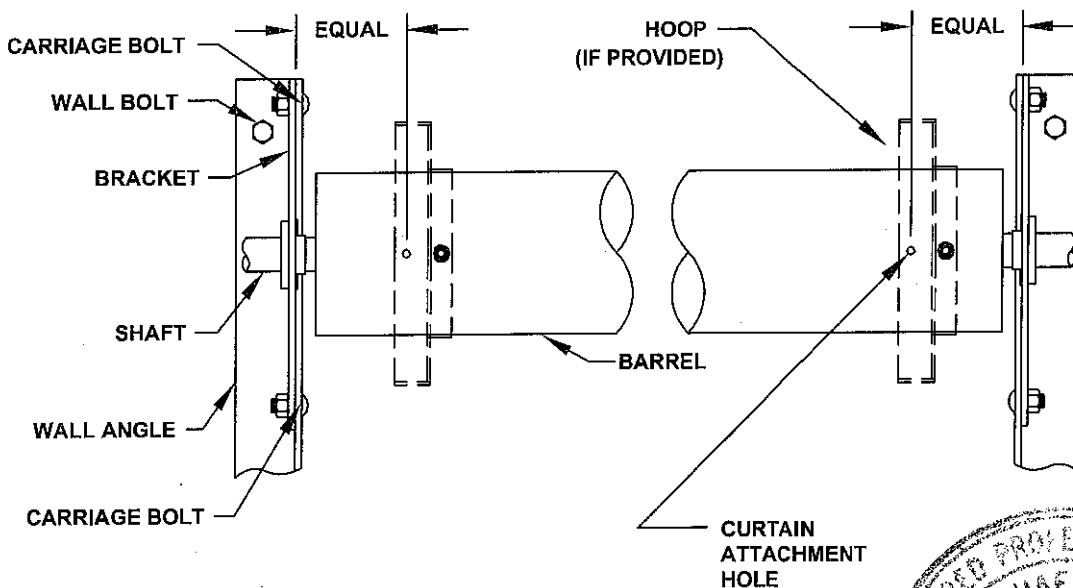
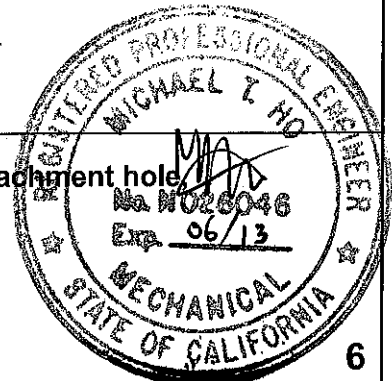

FIG 9

- 4) Position the barrel, with an equal distance from the first curtain attachment hole to the inside face of both brackets. See FIG 9.



CURTAIN ASSEMBLY FOR SERVICE DOORS

▲ IMPORTANT

BE SURE THAT THE TENSION SHAFT IS FREE TO ROTATE
DO NOT INSTALL TENSION WHEEL AT THIS TIME

- 1) PLACE THE ROLLED CURTAIN BELOW THE BARREL ASSEMBLY. HOIST THE CURTAIN APPROXIMATELY 3 FEET BELOW THE BARREL AND SUSPEND IT THERE BY MEANS OF TWO OR MORE SLINGS.

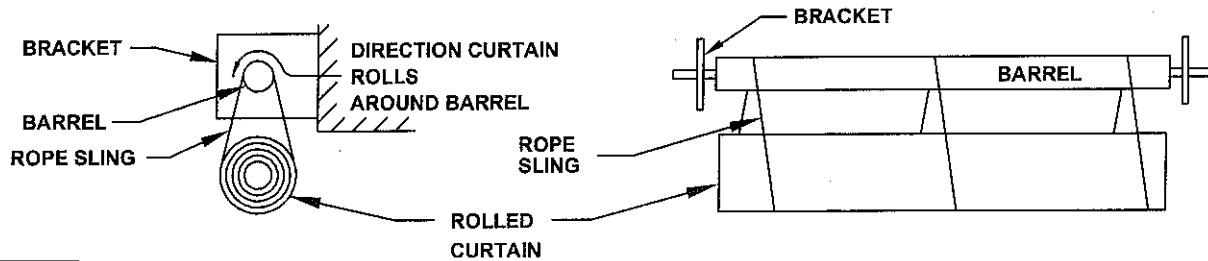

FIG 10

- 2) USING SLINGS TIED THROUGH THE CENTER HOLE OF THE TOP SLAT OF THE CURTAIN; WRAP THE SLINGS AROUND THE BARREL IN THE DIRECTION OF COIL UP ROTATION, PULL THE TOP SLAT UP AROUND THE BARREL. IF HOOPS ARE USED; PLACE IN LINE WITH THE HOLES IN THE TOP SLAT, AND WITH THE TOP SLAT LINED UP STRAIGHT ON THE BARREL, SECURE THE HOOPS TO THE BARREL.

▲ IMPORTANT

BE SURE THAT THE ENDS OF THE CURTAIN ARE EQUIDISTANT
FROM THE INSIDE FACES OF THE BRACKETS

- 3) IF YOUR DOOR HAS A MEANS OF MANUALLY OPERATING, USE IT TO ROLL THE CURTAIN ONTO THE BARREL.
- 4) IF YOUR DOOR IS THE PUSH-UP TYPE, USE A TENSIONING BAR INSERTED INTO THE TENSION WHEEL TO ROTATE THE BARREL WHILE ROLLING THE CURTAIN ONTO THE BARREL. ROTATE THE TENSION WHEEL IN THE SAME DIRECTION THE BARREL TURNS WHEN THE CURTAIN ROLLS ONTO IT.
- 5) WITH THE CURTAIN COMPLETELY ROLLED ONTO THE BARREL, FEED THE BOTTOM BAR INTO THE GUIDES AND ATTACH THE STOPS AS SHOWN IN FIG 11.

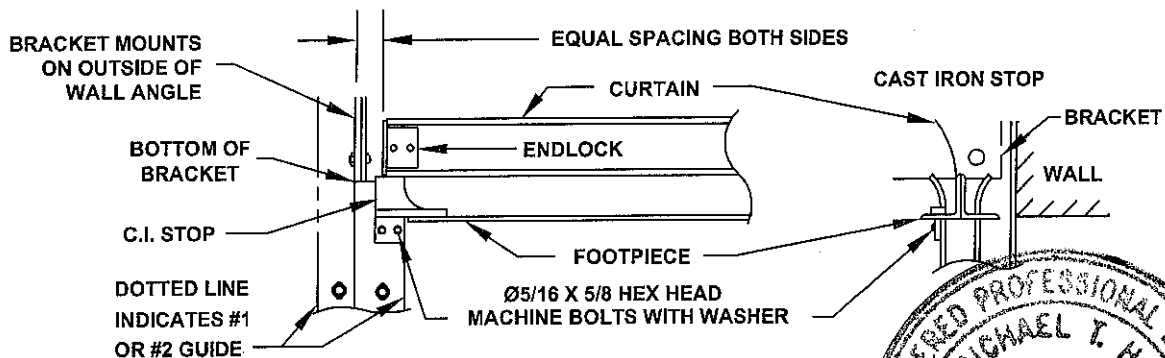
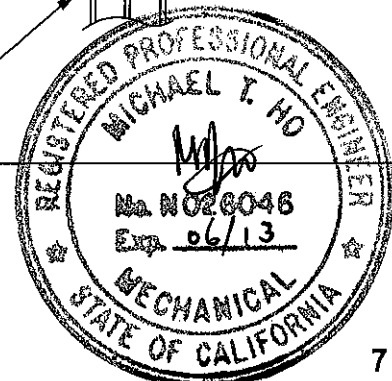

FIG 11



TENSIONING INSTRUCTIONS STANDARD TENSION WHEEL

⚠ WARNING

SERIOUS INJURY MAY BE INCURRED IF THE CURTAIN IS NOT FULLY COILED ON THE BARREL WHILE MAKING ADJUSTMENTS TO THE TENSION ASSEMBLY.

- 1) Raise the curtain to the full open position.
- 2) Install Tension Wheel onto Tension Shaft.
- 3) Rotate the tension wheel, by means of a bar inserted into the tension wheel. See installation information sheet for number of turns. Rotate in direction the curtain normally winds onto the barrel. See FIG 12.
- 4) Lock the tension wheel to the bracket with the supplied bolt. The bolt can be found in the angle clip that is welded to the bracket.
- 5) Test the door for operation. The balance should be such that the door remains stationary when at the top and bottom of the opening.

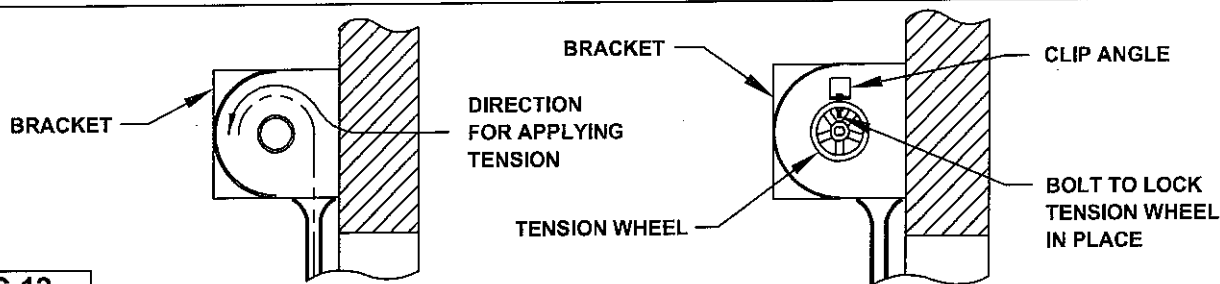

FIG 12

TENSIONING INSTRUCTIONS SPECIAL TENSION SPROCKET

- 1) Raise the curtain to the full open position. Tension should now be applied to springs by use of the tension wheel and tension sprocket. (Tension sprocket should be rotated in the same direction the barrel rotates when rolling up curtain on barrel) The number of turns to apply to the tension sprocket will be approximately two turns. The tension sprocket is bolted to the bracket with two $\text{\O}7/8$ Grade 5 fasteners. See FIG 13.

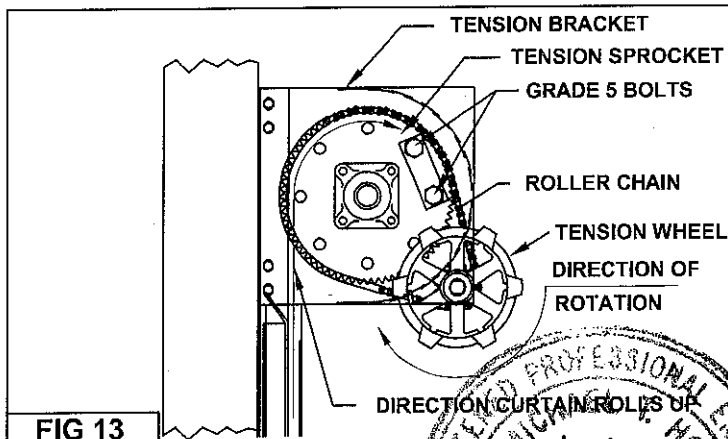
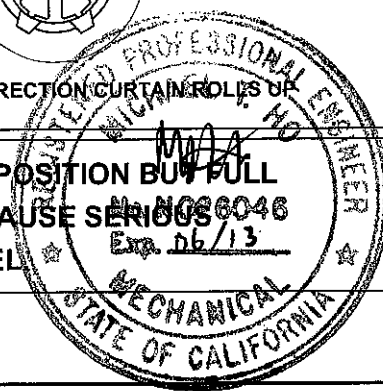

FIG 13

⚠ WARNING

DONT MAKE ADJUSTMENTS TO TENSION WHEEL AT ANY POSITION BUT FULL OPEN POSITION AS SPRINGS ARE WOUND UP AND MAY CAUSE SERIOUS INJURY TO A PERSON TRYING TO ADJUST TENSION WHEEL



HOOD SUPPORT MOUNTING INSTRUCTION

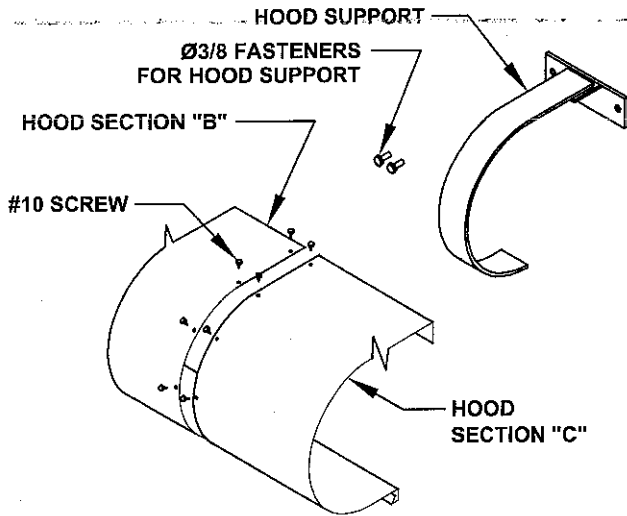

MULTI-SECTION HOOD ASSEMBLY

UP TO 26" BRACKETS

FIG 14

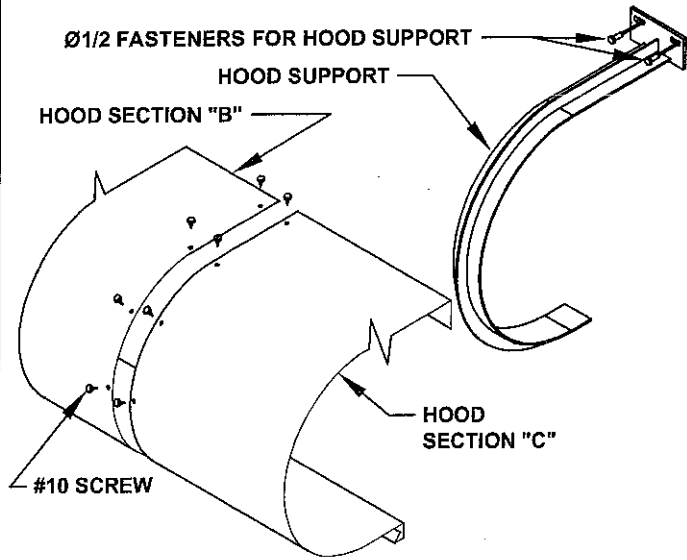

MULTI-SECTION HOOD ASSEMBLY

BRACKETS 28" AND OVER

FIG 15

Assembly Multi Section Hood:

- 1) Verify support size by comparing to Bracket Plate Hood Band.
- 2) Locate support as per Table 2.
- 3) Layout and drill wall for hood support bolts (2 bolts per support) and attach hood support(s) to wall.
- 4) With the hood sections over the support, butt hood ends together, and center on the hood support(s). Cope ends of top flange if required.
- 5) Drill $\varnothing.157$ hole thru the hood and support. Fasten together with the #10 self tapping machine screws provided. Note: Screws should not interfere w/curtain; Verify.

TABLE 1				
	MOUNTING MATERIAL	DRILL SIZE	DRILL DEPTH	MOUNTING BOLT
BRACKETS UP TO 26"	MASONRY/CONCRETE	3/8" CARBIDE	2"	$\varnothing 3/8$ " WEDGE ANCHOR
	WOOD	$\varnothing 3/16$ "	1"	$\varnothing 3/8$ " X 2" LAG SCREW
	STEEL	$\varnothing 5/16$ " (TAP 3/8-16)	1"	$\varnothing 3/8$ " X 1" HHMB
BRACKETS 28" AND OVER	MASONRY/CONCRETE	1/2" CARBIDE	3"	$\varnothing 1/2$ X 2-3/4" WEDGE ANCHOR
	WOOD	$\varnothing 5/16$ "	2-1/2"	$\varnothing 1/2$ X 3 LAG SCREW
	STEEL	$\varnothing 7/16$ " (TAP 1/2-13)	2"	$\varnothing 1/2$ X 1-1/2 HHMB

TABLE 2			
HOOD LENGTH	SECTIONS	SUPPORTS	LOCATION
0 TO 14'-0"	1	0	
14'-0 1/8" TO 28'-0"	2	1	CENTER OF HOOD
28'-0 1/8" TO 42'-0"	3	2	AT 1/3 POINTS
42'-0 1/8" TO 56'-0"	4	3	AT 1/4 POINTS

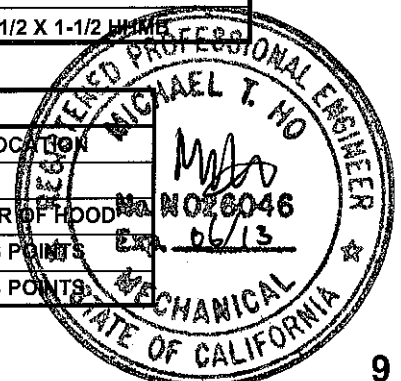

HOOD INSTALLATION

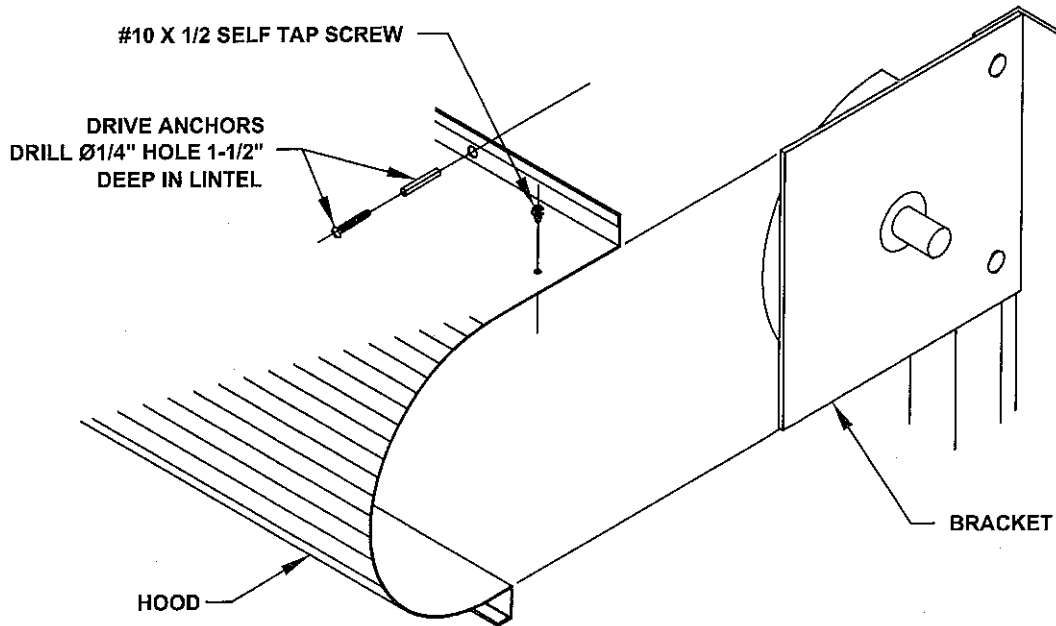

FIG 16

SERVICE/FIRE DOORS HOOD FLANGE UP

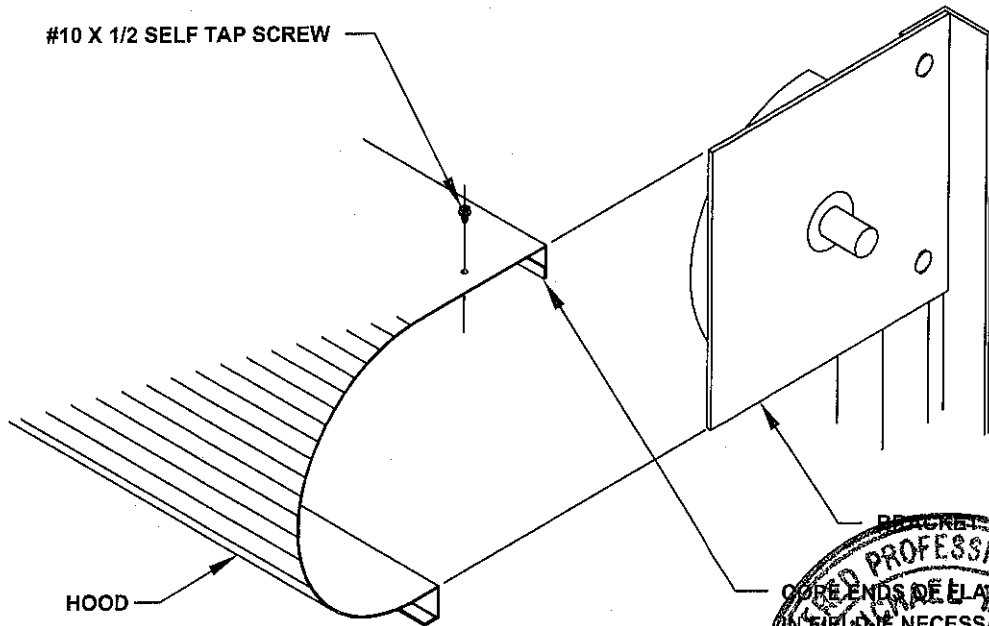
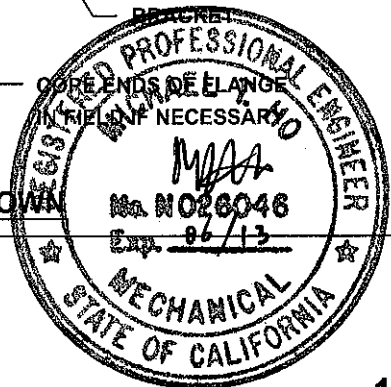

FIG 17

SERVICE/FIRE DOORS HOOD FLANGE DOWN



HAND CHAIN OPERATOR INSTALLATION

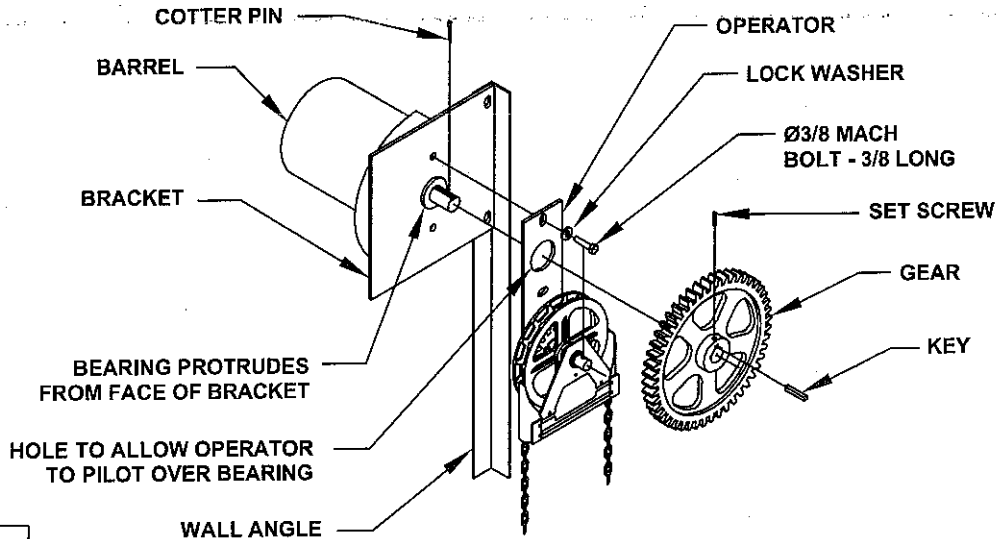

FIG 18

- 1) Raise brackets and barrel into position and bolt brackets to wall angle.
- 2) Bolt operator to bracket.
- 3) Insert key in keyway and tighten set screw.

NOTE: Right hand operator shown.

Left hand operator opposite as shown.

DOORS WITH SINGLE GEAR SYSTEM: Preposition gear to mesh with 3" pinion before installing operator on bracket.

DOORS WITH DOUBLE GEAR SYSTEM: Remove all gears from operator, install operator on bracket, then reinstall gears.

CRANK GEARBOX ASSY - WORM GEAR TYPE

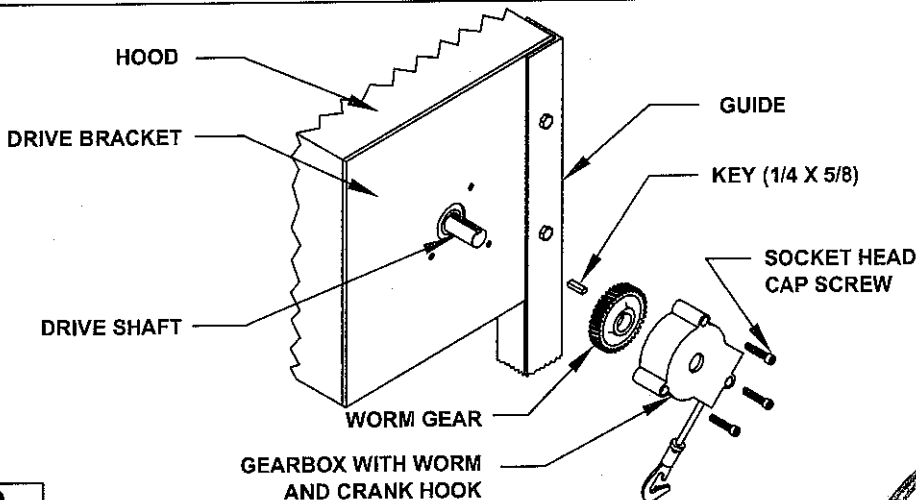
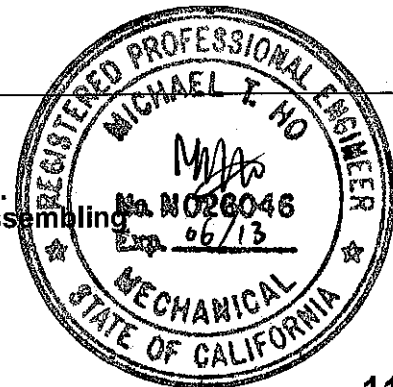

FIG 19

NOTE:

- 1) Worm wheel and gearbox are shipped mounted to bracket.
- 2) Unbolt gearbox and assemble over drive shaft as shown above.
- 3) On between jamb doors, this is usually easiest done prior to assembling brackets to guides.



SD/FD/GRILLE GUIDE MOUNTED CRANK OPERATED INSTALLATION INSTRUCTION

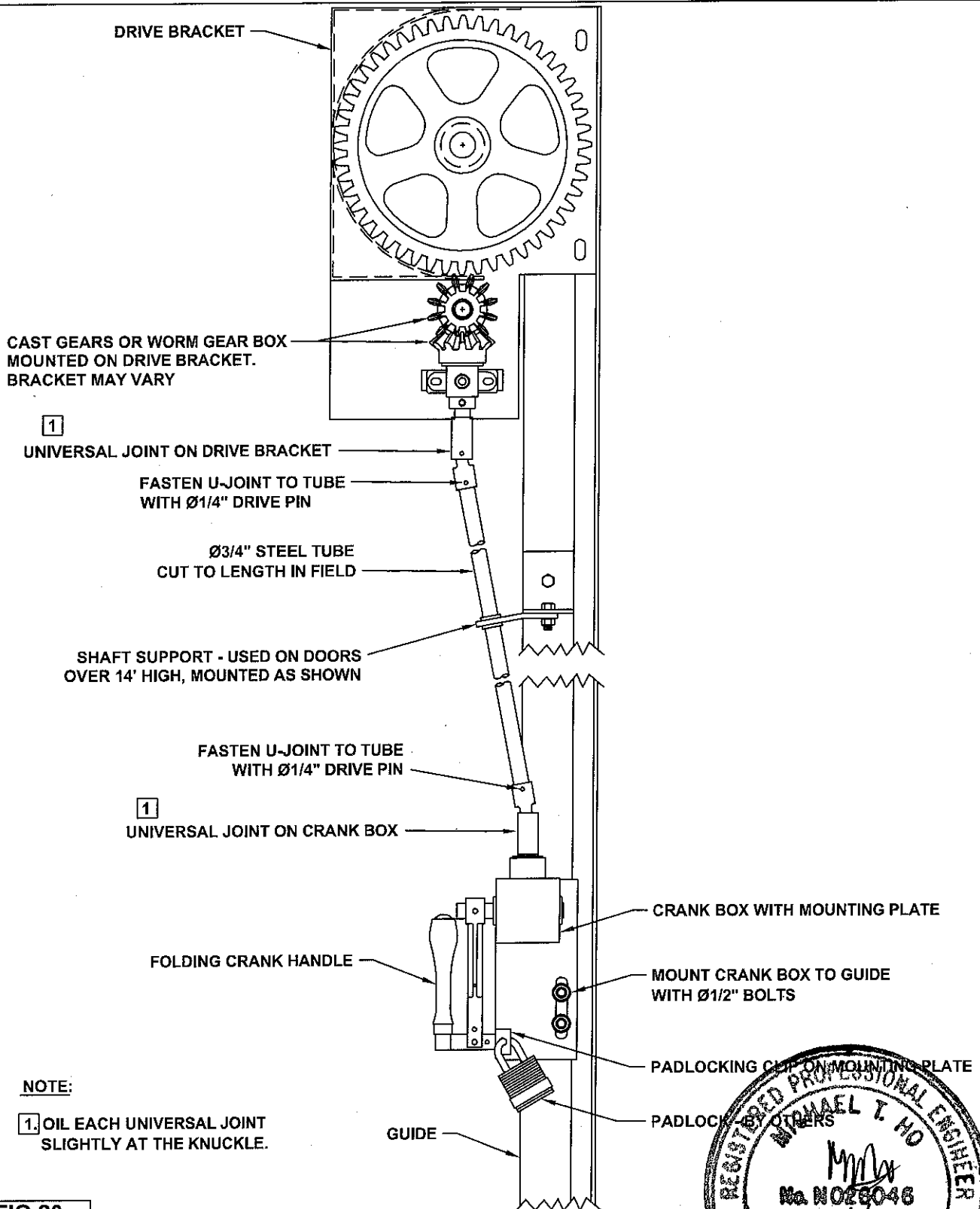
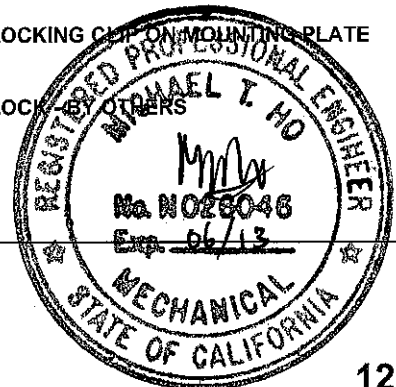

FIG 20



SD/FD/GRILLE GUIDE MOUNTED THRU-WALL CRANK OPERATED INSTALLATION INSTRUCTION

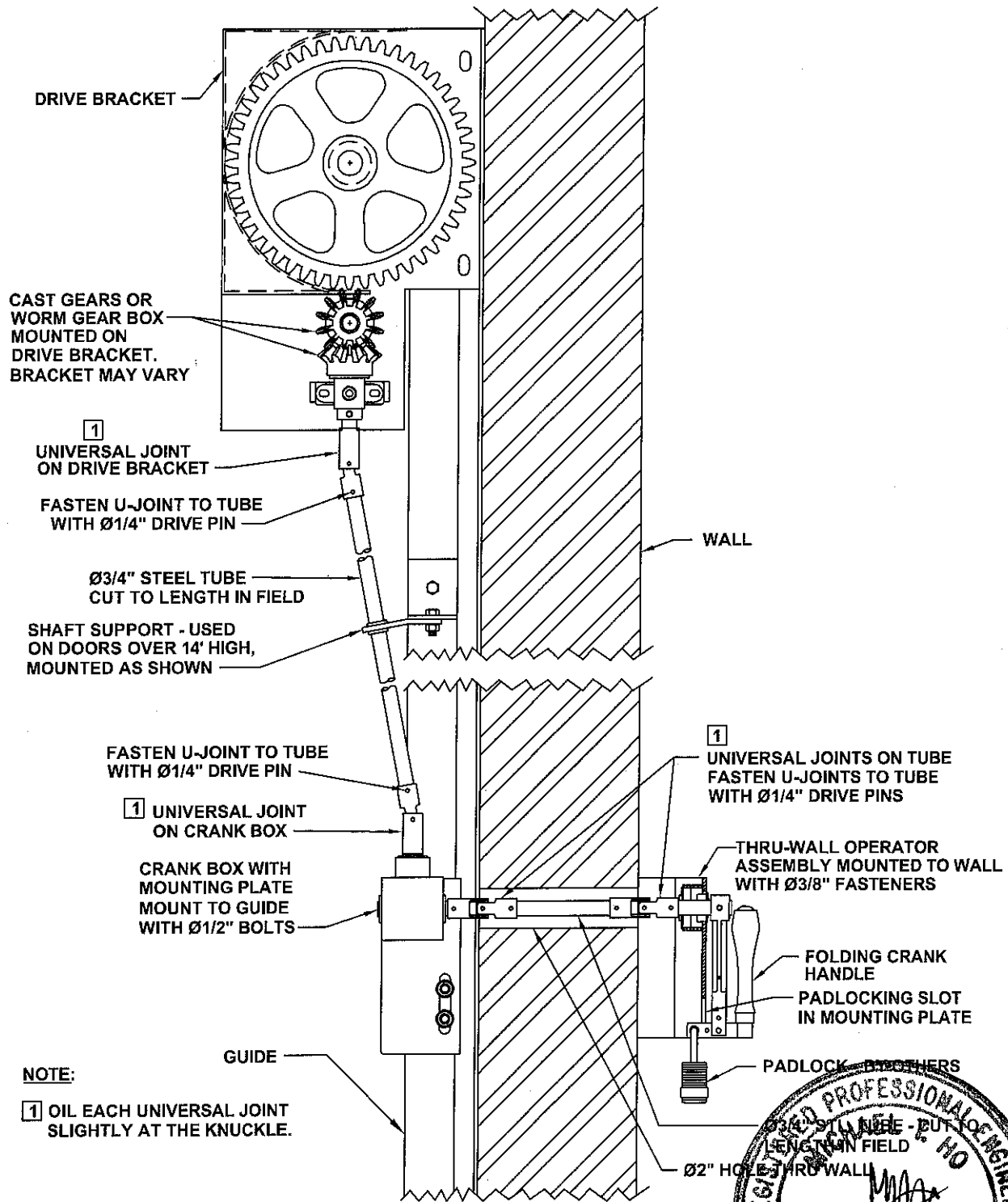
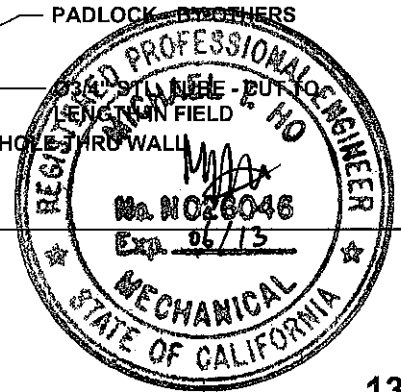

FIG 21



THRU-WALL CHAIN OPERATED ASSEMBLY

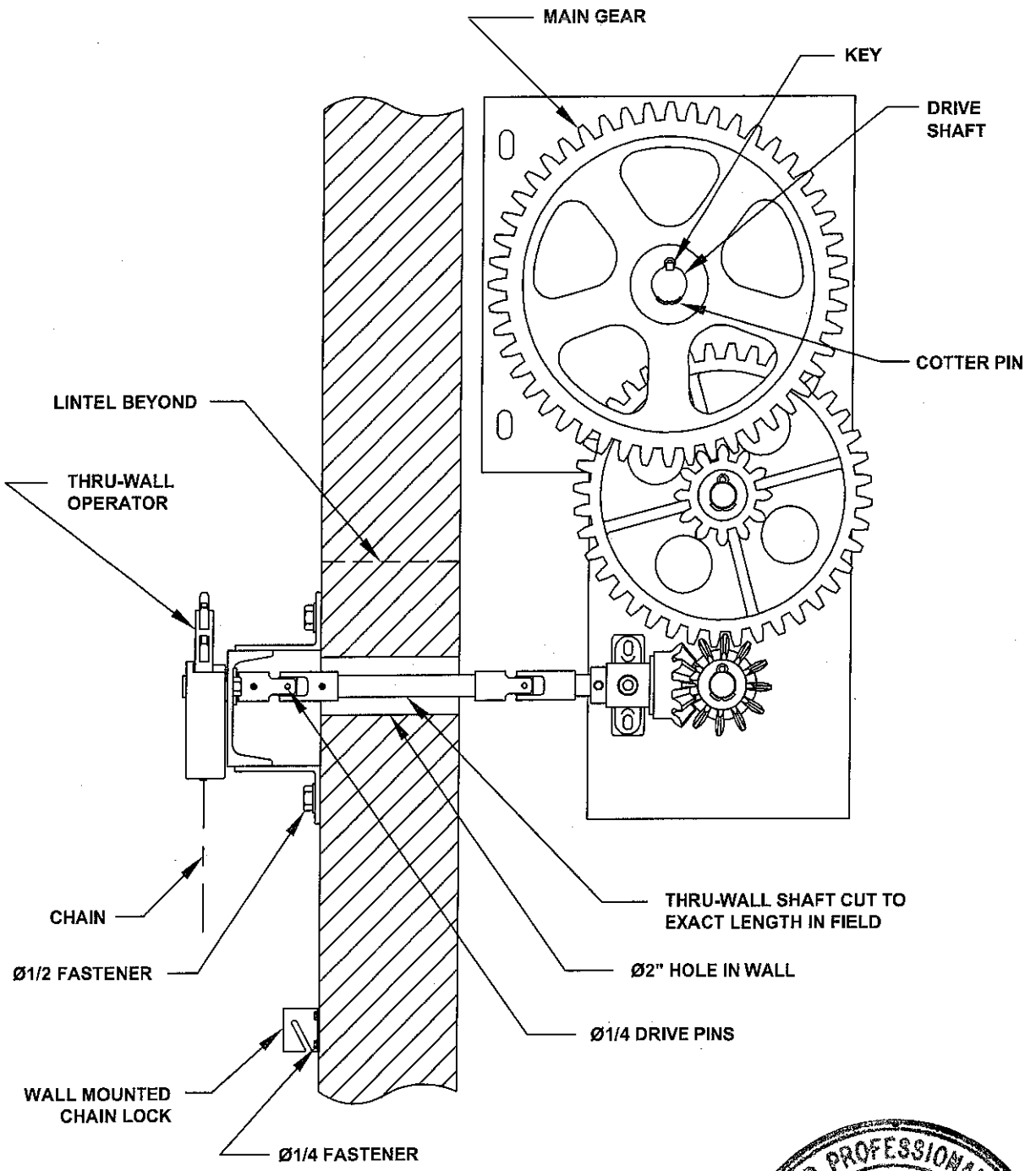
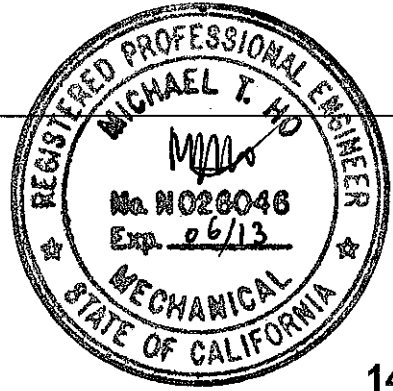
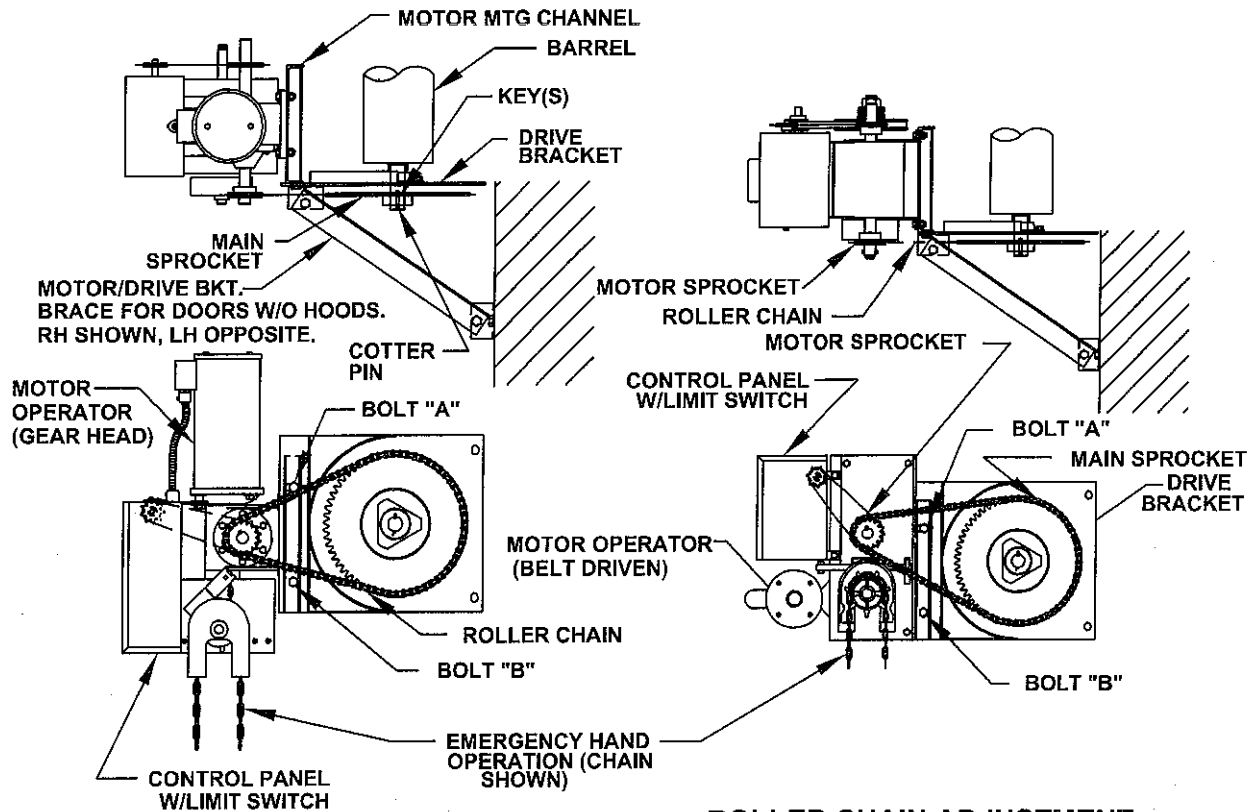

FIG 22



VERTICALLY MOUNTED MOTOR OPERATOR

RIGHT HAND IS SHOWN - LEFT HAND IS OPPOSITE



ROLLER CHAIN ADJUSTMENT

1. LOOSEN BOLT "A".
2. TIGHTEN CHAIN BY PIVOTING MOTOR MTG. CHANNEL ABOUT BOLT "B".
3. RETIGHTEN BOLT "A".

CAUTION: DOORS INSTALLED WITHOUT HOODS MUST HAVE MOTOR/BKT. BRACE INSTALLED TO AVOID FLEXING OF BRACKET AND POSSIBLE INJURY.

1) AFTER DOOR IS INSTALLED AND BRACKET PLATES ARE PERPENDICULAR TO WALL, ATTACH MOTOR/BKT BRACE TO BRACKET AND WALL AS SHOWN

2) MAKE SURE THAT BOLTS ARE TIGHT AND BRACKET PLATE IS PERPENDICULAR TO WALL.

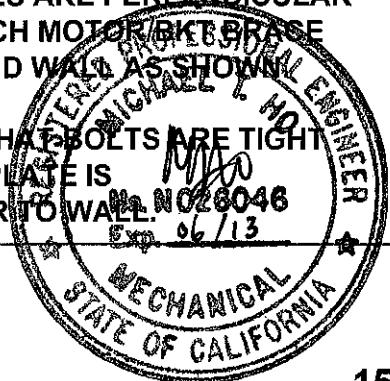
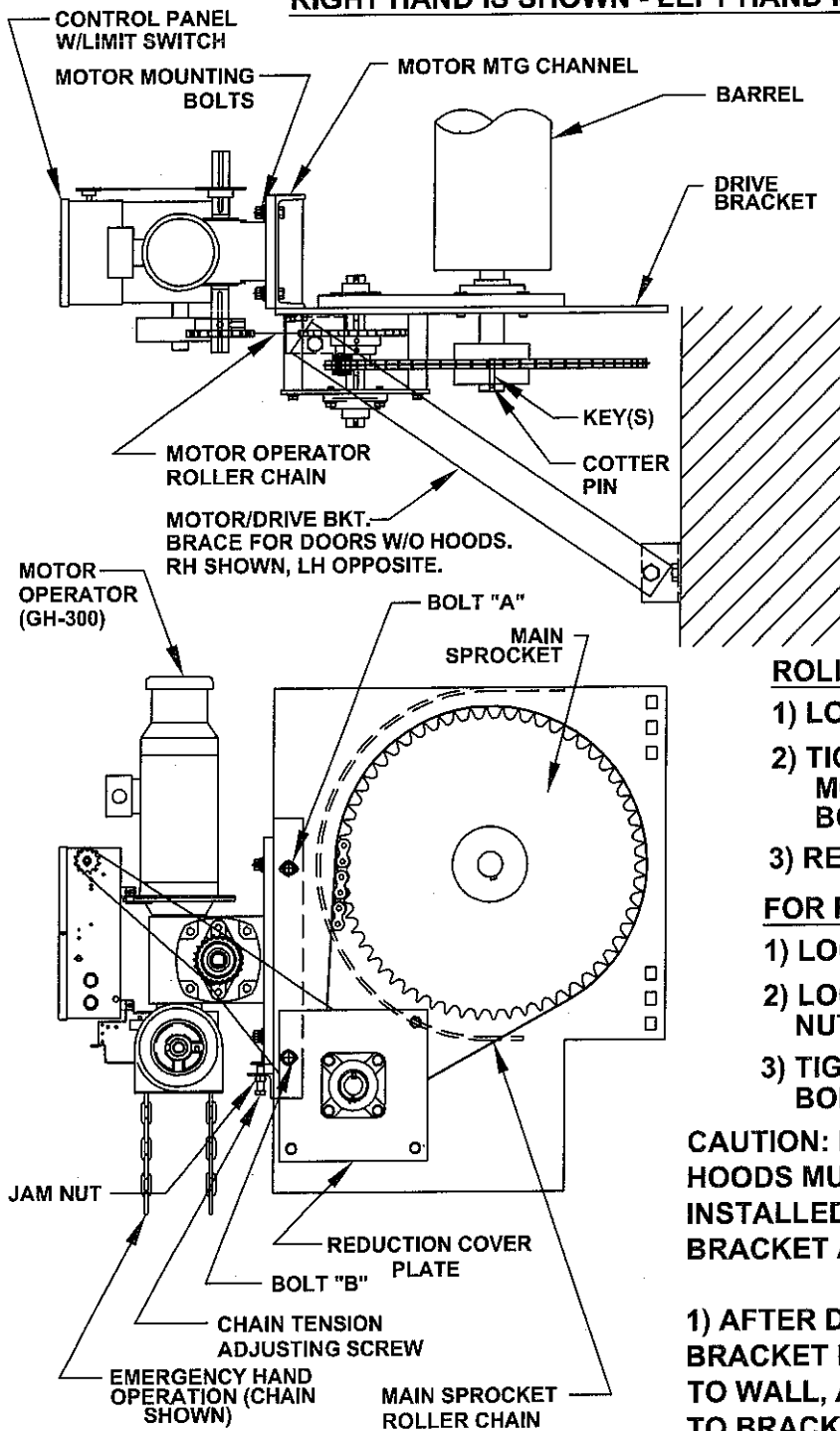

FIG 23

VERTICALLY MOUNTED GH MOTOR OPERATOR 3 HP DOUBLE REDUCTION BRACKET

RIGHT HAND IS SHOWN - LEFT HAND IS OPPOSITE



ROLLER CHAIN ADJUSTMENT

- 1) LOOSEN BOLT "A".
- 2) TIGHTEN CHAIN BY PIVOTING MOTOR MTG. CHANNEL ABOUT BOLT "B".
- 3) RETIGHTEN BOLT "A".

FOR FINE TUNING CHAIN TENSION

- 1) LOOSEN (4) MTR MTG BOLTS.
- 2) LOOSEN CHAIN TENSION JAM NUT AND ADJUST SCREW.
- 3) TIGHTEN JAM NUT & MTR MTG BOLTS.

CAUTION: DOORS INSTALLED WITHOUT HOODS MUST HAVE MOTOR/BKT. BRACE INSTALLED TO AVOID FLEXING OF BRACKET AND POSSIBLE INJURY.

1) AFTER DOOR IS INSTALLED AND BRACKET PLATES ARE PERPENDICULAR TO WALL, ATTACH MOTOR/BKT. BRACE TO BRACKET AND WALL AS SHOWN.

2) MAKE SURE THAT BOLTS ARE TIGHT AND BRACKET PLATE IS PERPENDICULAR TO WALL.

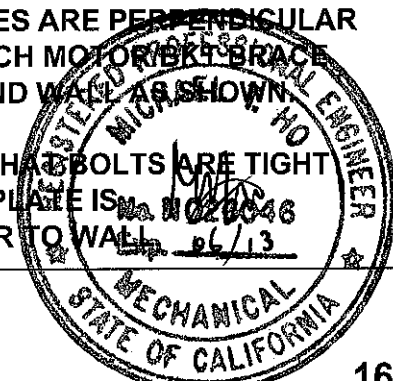
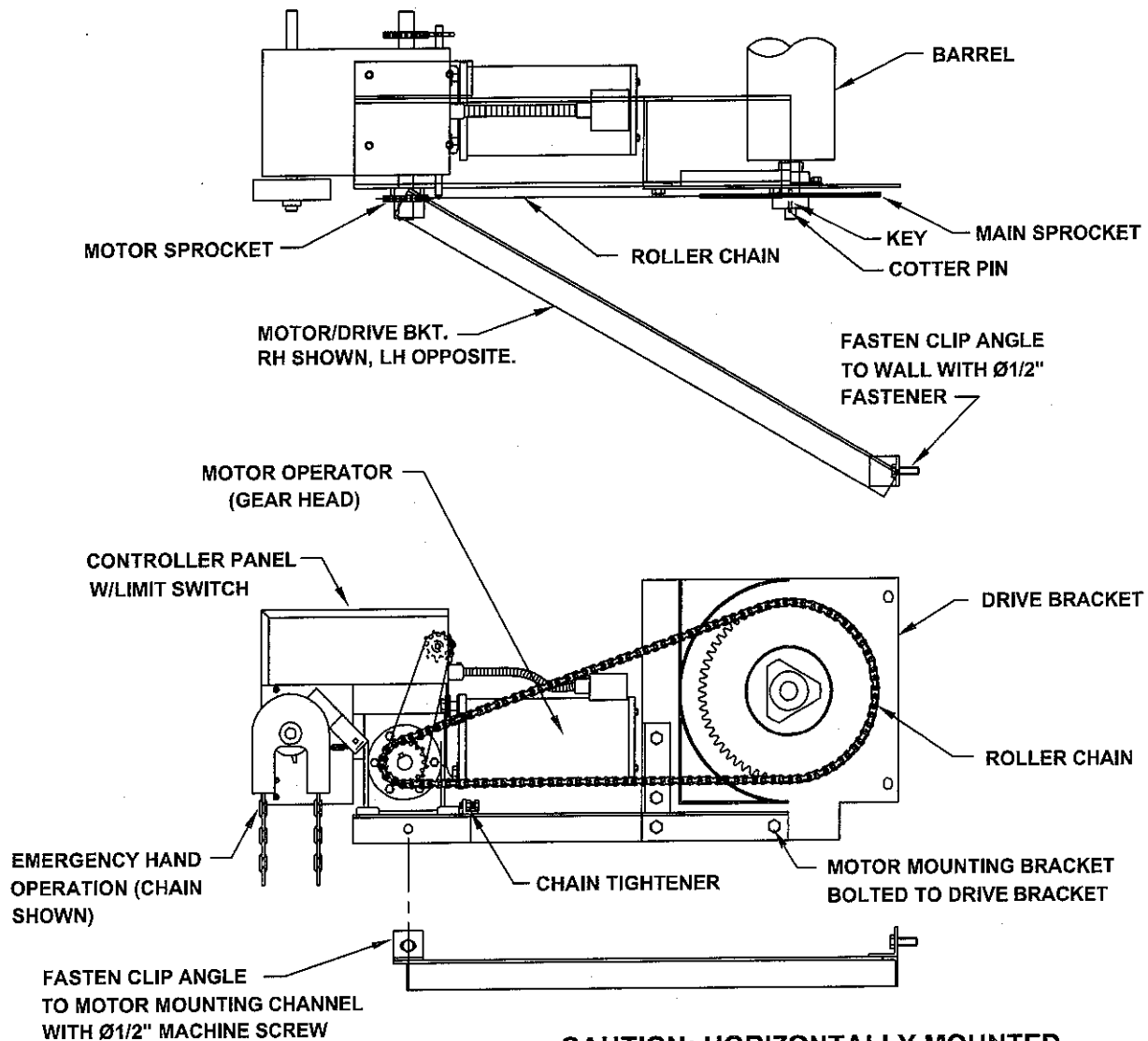

FIG 24

HORIZONTALLY MOUNTED GH MOTOR OPERATOR



CAUTION: HORIZONTALLY MOUNTED MOTORS MUST HAVE MOTOR/BKT. BRACE INSTALLED TO AVOID FLEXING OF BRACKET AND POSSIBLE INJURY.

1) AFTER DOOR IS INSTALLED AND BRACKET PLATES ARE PERPENDICULAR TO WALL, ATTACH MOTOR/BKT BRACE TO BRACKET AND WALL AS SHOWN.

2) MAKE SURE THAT BOLTS ARE TIGHT AND BRACKET PLATE IS PERPENDICULAR TO WALL.

FIG 25

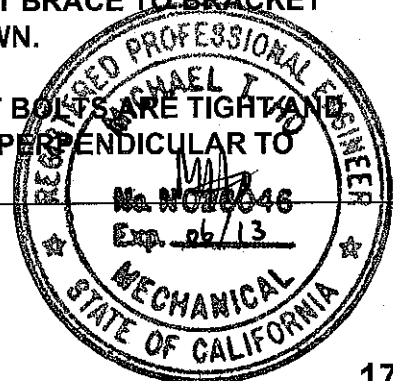

SIDE MOUNT/WALL MOUNT GH MOTOR OPERATOR

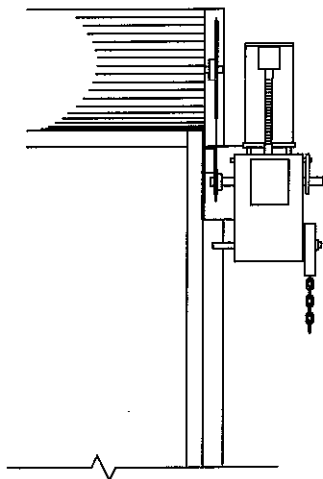

CAUTION: DOORS INSTALLED WITHOUT HOODS MUST HAVE MOTOR/BRK. BRACE INSTALLED TO AVOID FLEXING OF BRACKET AND POSSIBLE INJURY.

1) AFTER DOOR IS INSTALLED AND BRACKET PLATES ARE PERPENDICULAR TO WALL, ATTACH MOTOR/BKT BRACE TO BRACKET AND WALL AS SHOWN.

2) MAKE SURE THAT BOLTS ARE TIGHT AND BRACKET PLATE IS PERPENDICULAR TO WALL.

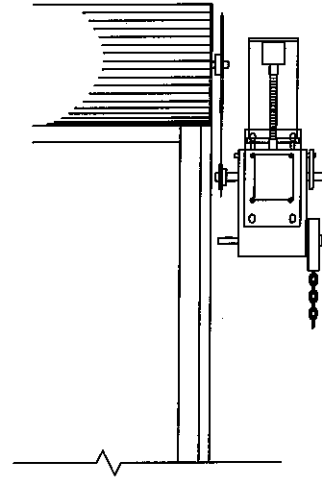

WALL MOUNTED GH OPERATOR

SIDE MOUNTED GH OPERATOR

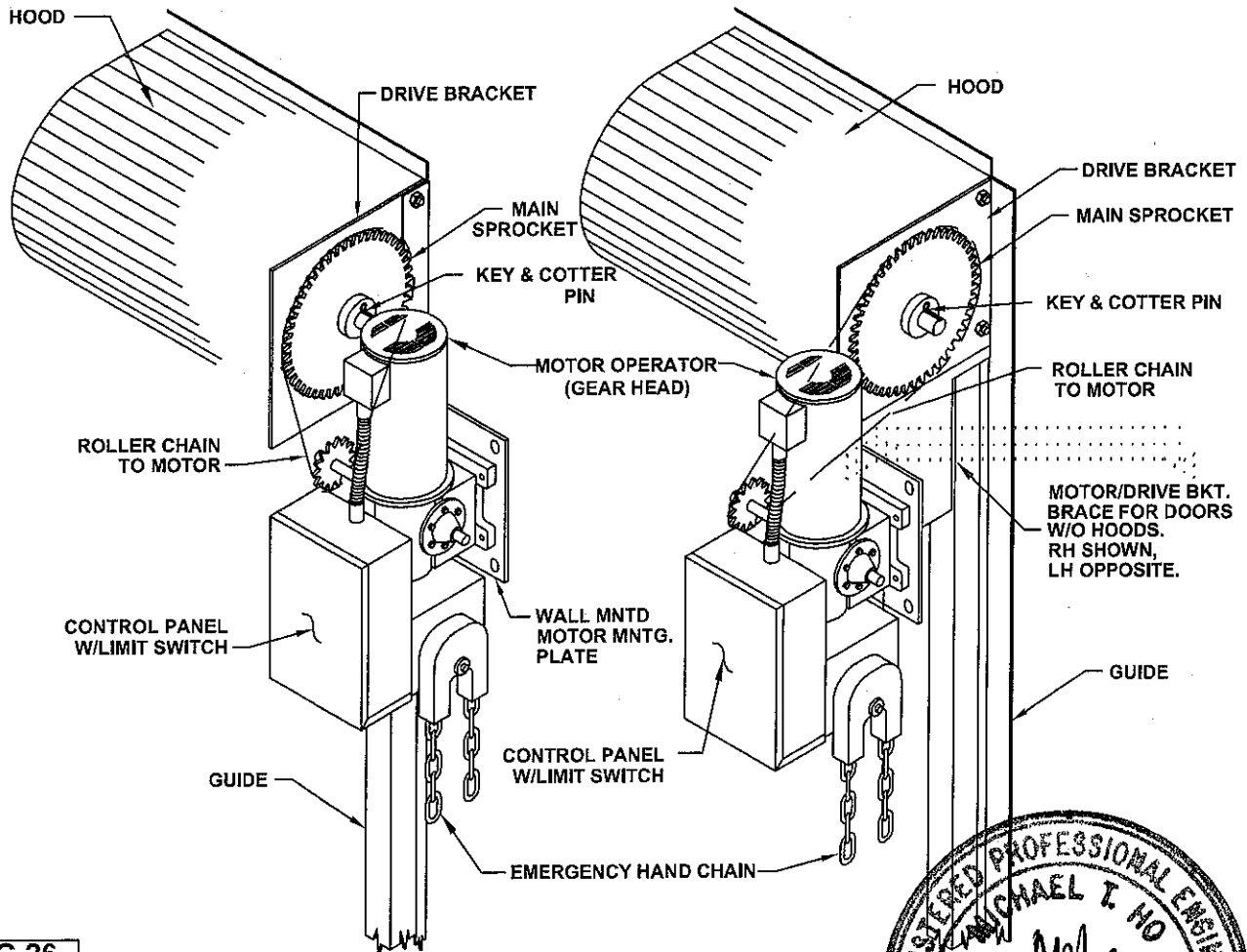
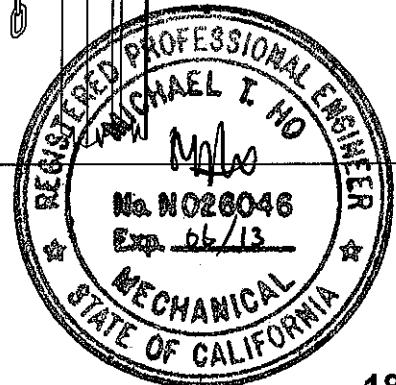

FIG 26



THRU WALL GH MOTOR OPERATOR

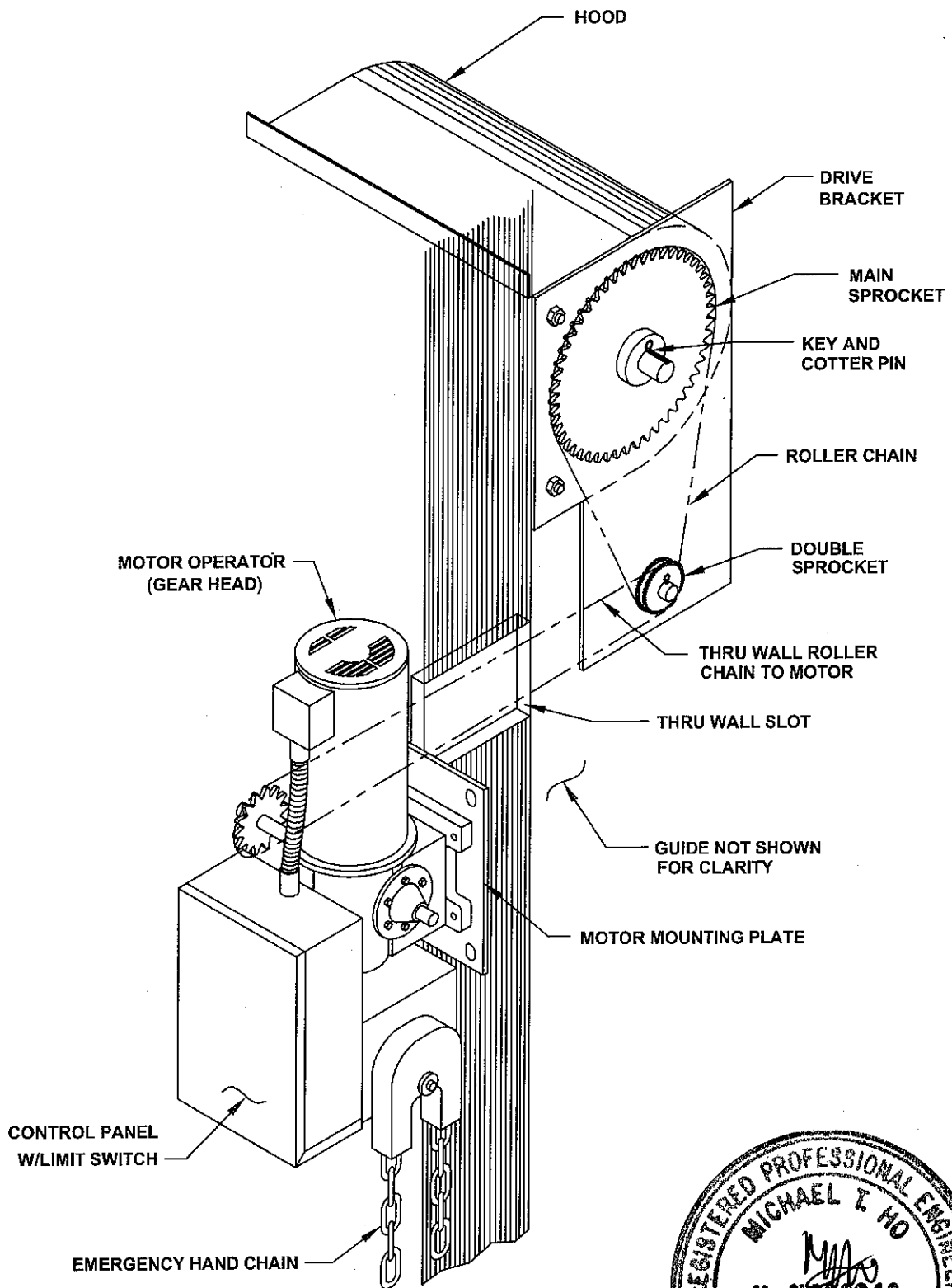
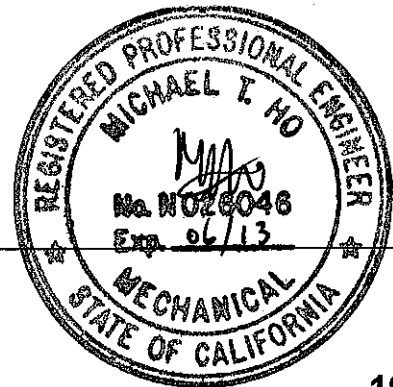
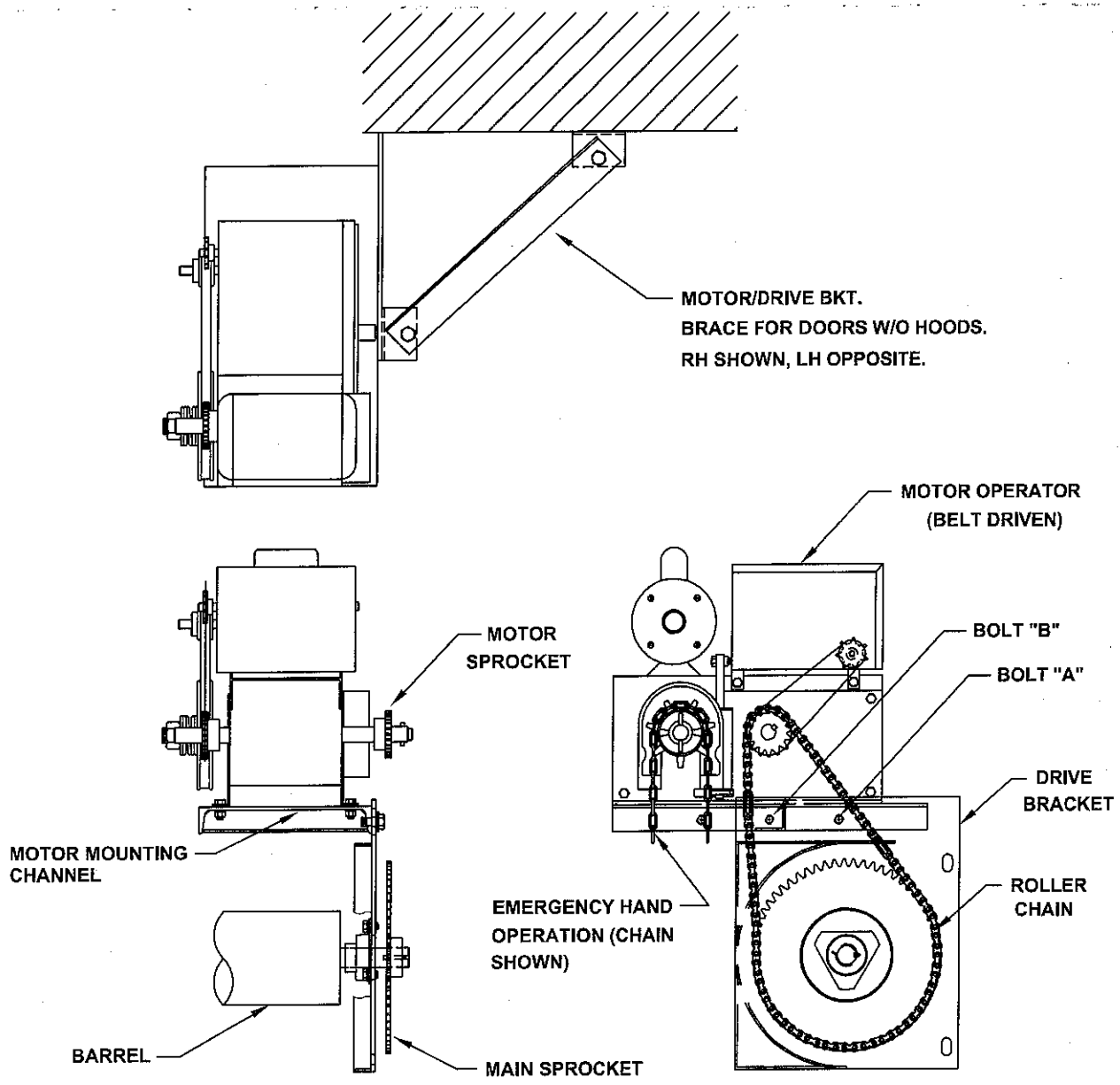

FIG 27



BELT DRIVE MOTOR BRACKET ASSY- TOP MOUNT



RIGHT HAND SHOWN - LEFT HAND IS OPPOSITE

CAUTION: DOORS INSTALLED WITHOUT HOODS MUST HAVE MOTOR/BKT. BRACE INSTALLED TO AVOID FLEXING OF BRACKET AND POSSIBLE INJURY.

ROLLER CHAIN ADJUSTMENT

- 1) LOOSEN BOLT "A".
- 2) TIGHTEN CHAIN BY PIVOTING MOTOR MTG. CHANNEL ABOUT BOLT "B".
- 3) RETIGHTEN BOLT "A".

- 1) AFTER DOOR IS INSTALLED AND BRACKET PLATES ARE PERPENDICULAR TO WALL ATTACH MOTOR/BKT BRACE TO BRACKET AND WALL AS SHOWN.
- 2) MAKE SURE THAT BOLTS ARE TIGHT AND BRACKET PLATE IS PERPENDICULAR TO WALL.

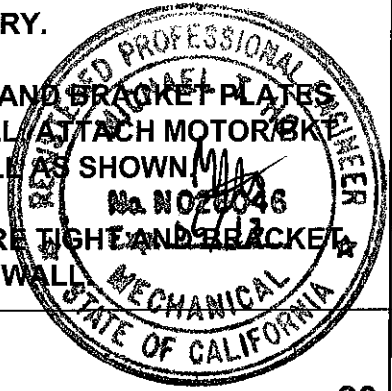

FIG 28

INSTRUCTIONS FOR SETTING ROTARY LIMIT SWITCH

**CAUTION: ONLY ADJUST THE ROTARY LIMIT SWITCH WITH THE POWER "OFF".
ONLY TRAINED PERSONNEL SHOULD SET OR ADJUST THE LIMIT SWITCH.**

- 1) USING THE MANUAL OPERATOR, LOWER OR RAISE THE CURTAIN TO THE MIDPOINT OF THE OPENING.
- 2) OPEN THE LIMIT SWITCH BOX AND IDENTIFY ALL PARTS:
Ⓐ DETENT PLATE Ⓑ CAM NUT Ⓒ BASIC SWITCHES
- 3) DEPRESS THE SPRING LOADED DETENT PLATE AND ROTATE EACH CAM NUT APPROXIMATELY 1/8" FROM THE BASIC SWITCHES AS SHOWN BELOW.

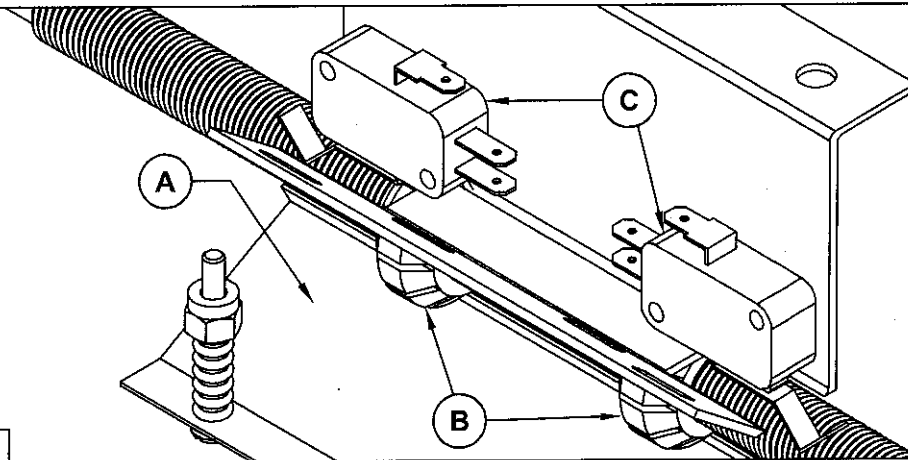
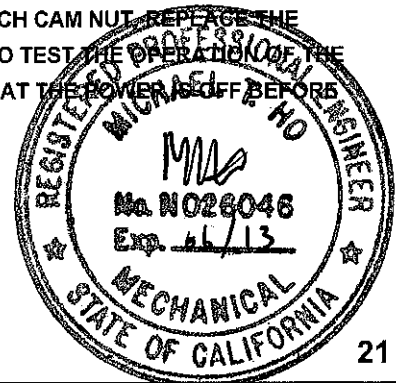

FIG 29

- 4) APPLY POWER TO THE MOTOR AND TEST THE OPERATION OF THE DOOR. AS THE DOOR IS OPENING THE "OPEN" CAM NUT SHOULD BE TRAVELING TOWARDS THE "OPEN" BASIC SWITCH. AS THE DOOR IS CLOSING THE "CLOSE" CAM NUT SHOULD BE TRAVELING TOWARDS THE "CLOSE" BASIC SWITCH. THE CAM NUTS ARE DESIGNED TO ACTIVATE THE BASIC SWITCHES AND TERMINATE THE TRAVEL OF THE DOOR.
- 5) **IMPORTANT:** CHECK THAT THE MOTOR IS CORRECTLY WIRED IN REGARDS TO ROTATION AND DIRECTION. OPERATE THE OPEN AND CLOSE FUNCTIONS. IF THE MODE OF OPERATION IS INCORRECT (WHEN THE "OPEN" FUNCTIONS OF THE CONTROL STATION MAKES THE DOOR CLOSE OR THE "CLOSE" FUNCTIONS OF THE CONTROL STATION MAKES THE DOOR OPEN) OR THE ROTATION DIRECTION OF THE CAM NUT IS INCORRECT (CAM NUT TRAVELS TOWARD THE "OPEN" BASIC SWITCH WHEN CLOSING AND THE "CLOSE" BASIC SWITCH WHEN OPENING) DISCONTINUE OPERATION OF THE DOOR AND CHECK THE WIRING. ALL WIRING MUST BE CORRECT BEFORE PROCEEDING.
- 6) ONCE THE CORRECT ROTATION AND ORIENTATION OF THE CONTROL FUNCTIONS AND BASIC SWITCHES HAS BEEN DETERMINED, PROCEED WITH THE FINALIZED SETTING OF THE ROTARY LIMIT SWITCH.
- 7) TURN POWER OFF. WITH THE MANUAL OPERATOR LOWER THE DOOR TO THE FULLY CLOSED POSITION. ROTATE THE "CLOSE" CAM NUT TOWARD THE "CLOSE" BASIC SWITCH UNTIL THE SWITCH CLICKS. THE "CLOSE" BASIC SWITCH IS NOW SET. RAISE THE DOOR TO THE FULLY OPEN POSITION. ROTATE THE "OPEN" CAM NUT TOWARD THE "OPEN" BASIC SWITCH UNTIL THE SWITCH CLICKS. THE OPEN BASIC SWITCH IS NOW SET.
- 8) MAKE SURE THAT THE DETENT PLATE IS FULLY ENGAGED IN THE SLOTS OF EACH CAM NUT. REPLACE THE COVER ON THE LIMIT SWITCH AND APPLY POWER TO THE MOTOR OPERATOR TO TEST THE OPERATION OF THE DOOR. IF FURTHER FINE TUNING ADJUSTMENTS ARE REQUIRED MAKE SURE THAT THE POWER IS OFF BEFORE ADJUSTMENTS ARE MADE.



SAFETY EDGE COIL CORD/ CORD REEL INSTALLATION INSIDE DOOR WITH MOTOR MOUNTED CONTROLLER

COIL CORD INSTALLATION INSTRUCTIONS:

- 1) LOCATE CONTROL PANEL KNOCK OUT CLOSEST TO DOOR OPENING & IN LINE WITH MALE CONNECTOR,
- 2) LOCATE COIL CORD/CORD REEL AS NOT TO INTERFERE WITH ROLLER CHAIN.
- 3) INSTALL ELBOW (AS SHOWN).
- 4) WIRE TO TERMINALS AS INDICATED ON WIRING DIAGRAM.
- 5) CONNECT TWIST LOCK PLUG (WIRE FEMALE TO COIL CORD/CORD REEL IF SHIPPED LOOSE).
- 6) TEST REVERSING BOTTOM BAR FOR CORRECT OPERATION.
- 7) ADJUST FEATHEREDGE SWITCH AS REQ'D. (SEE INSTRUCTIONS ON PAGE 23)

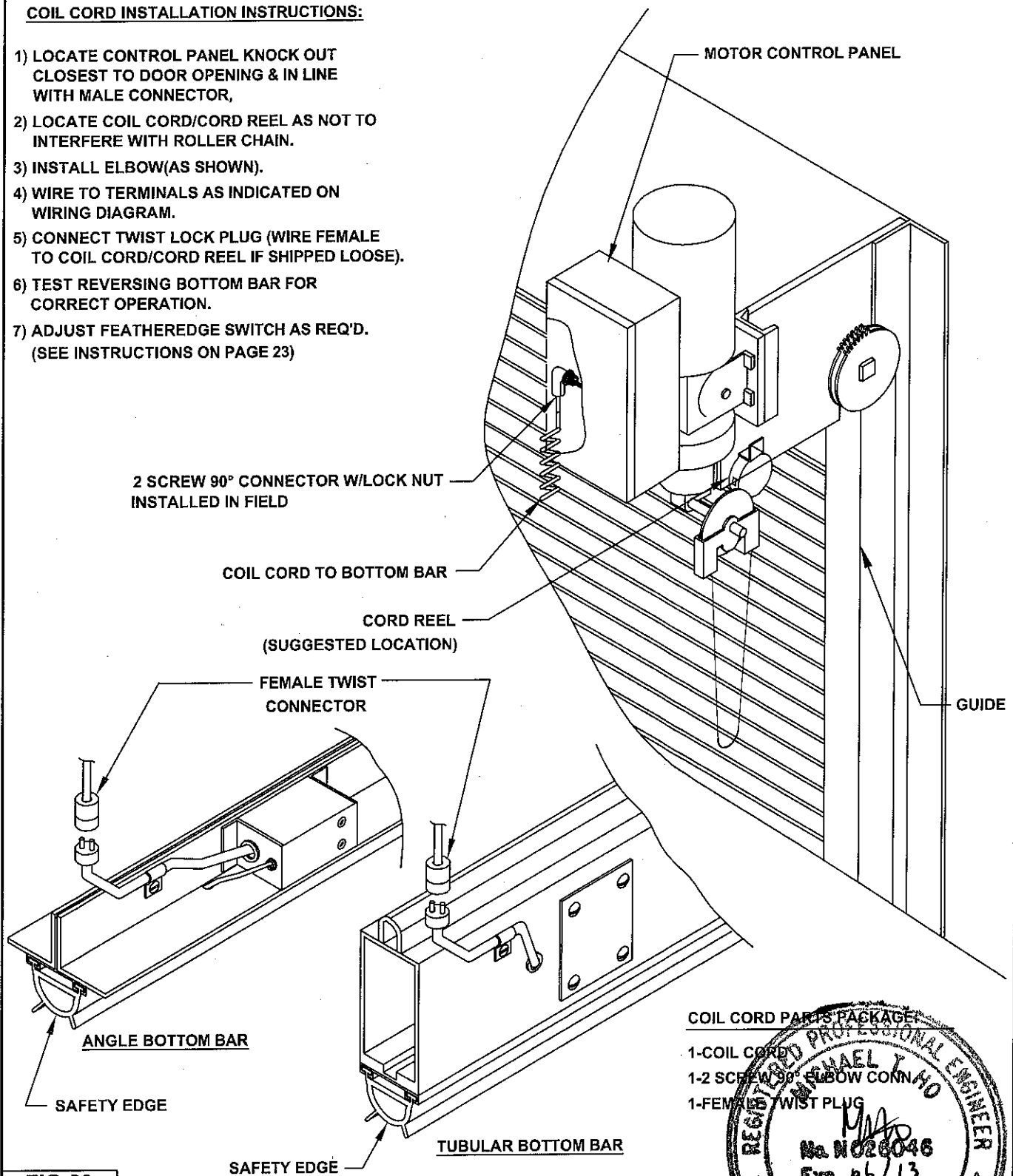

COIL CORD PARTS PACKAGE

- 1-COIL CORD
- 1-2 SCREW 90° ELBOW CONN
- 1-FEMALE TWIST PLUG

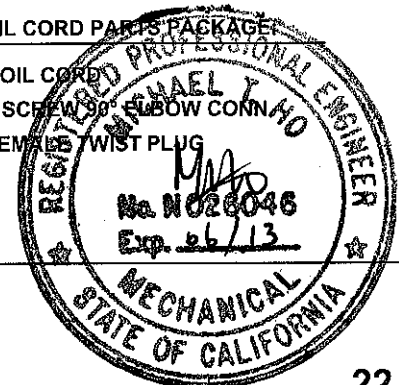

FIG 30

SAFETY EDGE COIL CORD/ CORD REEL INSTALLATION OUTSIDE AND ABOVE MOUNTED DOORS

MOTOR SHOWN RECTANGULAR & DOTTED FOR CLARITY
THE CONDUIT FROM THE CONDUIT BOX TO THE
CONTROLLER IS TO BE DONE IN FIELD

COIL CORD OPTION:
2 X 4 CONDUIT BOX

CORD REEL OPTION:
CONDUIT BOX W/2 PRG
OUTLET TO BE SUPPLIED
BY OTHERS.

COIL CORD/CORD REEL INSTALLATION:

- 1) FASTEN CONDUIT BOX W/MTG PLATE TO WALL AS SHOWN USING Ø1/4 FASTENERS.
- 2) INSTALL 2 SCREW 90° ELBOW AS SHOWN IF USING COIL CORD.
- 3) WIRE COIL CORD/CORD REEL AS INDICATED ON WIRING DIAGRAM.
- 4) CONNECT TWIST LOCK PLUG (WIRE FEMALE TO COIL CORD/CORD REEL IF SHIPPED LOOSE).
- 5) TEST REVERSING BOTTOM BAR FOR CORRECT OPERATION.
- 6) ADJUST FEATHEREDGE SWITCH AS REQ'D (SEE INST. ON PAGE 23)

USE (2) #12 PAN HD
SCREW W/SHIELDS FOR
MASONRY MTG.

CORD REEL

CORD REEL (SUGGESTED LOCATION)
SEE ABOVE DETAIL

COIL CORD PARTS PACKAGE:

- 1 - COIL CORD
- 2 - 2 SCREW 90° ELBOW
- 3 - FEMALE TWIST LOCK PLUG

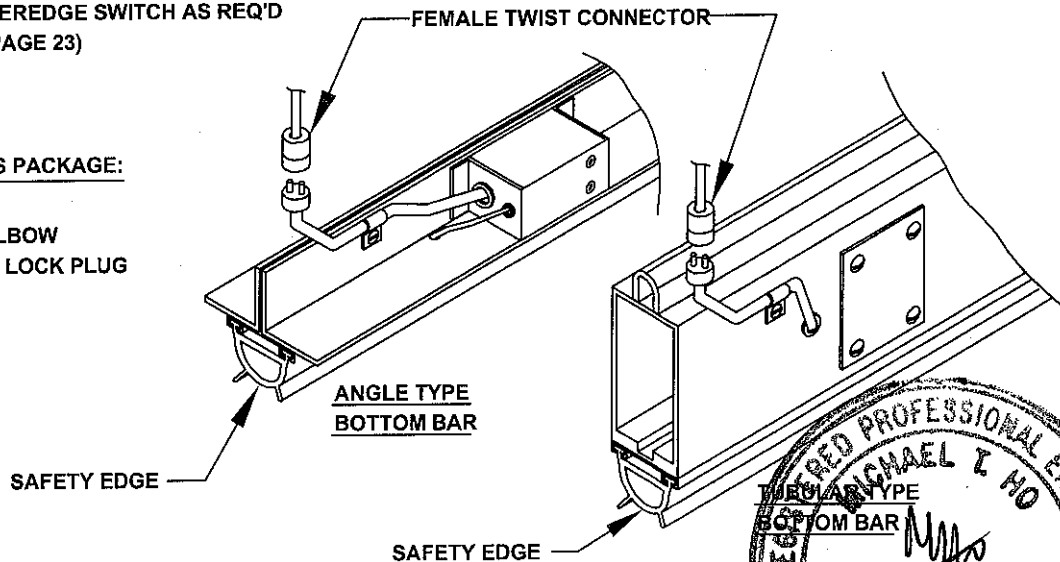
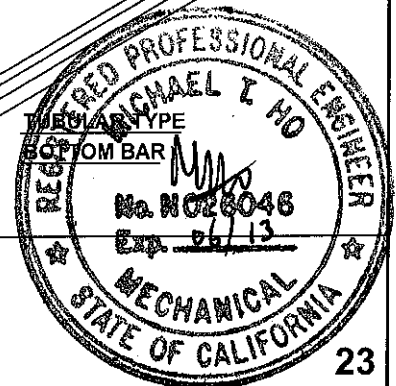

FIG 31



FAILSAFE SAFETY EDGE INSTALLATION INSTRUCTIONS

NOTE: DIODE IS PROVIDED PREWIRED INSIDE OF BOTTOM BAR. IF MOTOR MANUFACTURER HAS PROVIDED A DIODE SAVE AS A SPARE.

- 1) LOCATE CONTROL PANEL KNOCK OUT CLOSEST TO DOOR OPENING & IN LINE WITH MALE CONNECTOR.
- 2) LOCATE COIL CORD/CORD REEL AS NOT TO INTERFERE WITH ROLLER CHAIN.
- 3) WIRE TO TERMINALS AS INDICATED ON WIRING DIAGRAM. (NOTE: DIODE CONNECTION IS PREWIRED)
- 4) CONNECT TWIST LOCK PLUG. (WIRE FEMALE TO COIL CORD/CORD REEL IF SHIPPED LOOSE)
- 5) TEST REVERSING BOTTOM BAR FOR CORRECT OPERATION.
- 6) IF MOTOR DOES NOT OPERATE OR FAILSAFE RELAY SHOWS A FAULT CONDITION REVERSE POLARITY OF WIRES IN CONTROLLER. DO NOT MODIFY DIODE CONNECTION ON BOTTOM BAR.

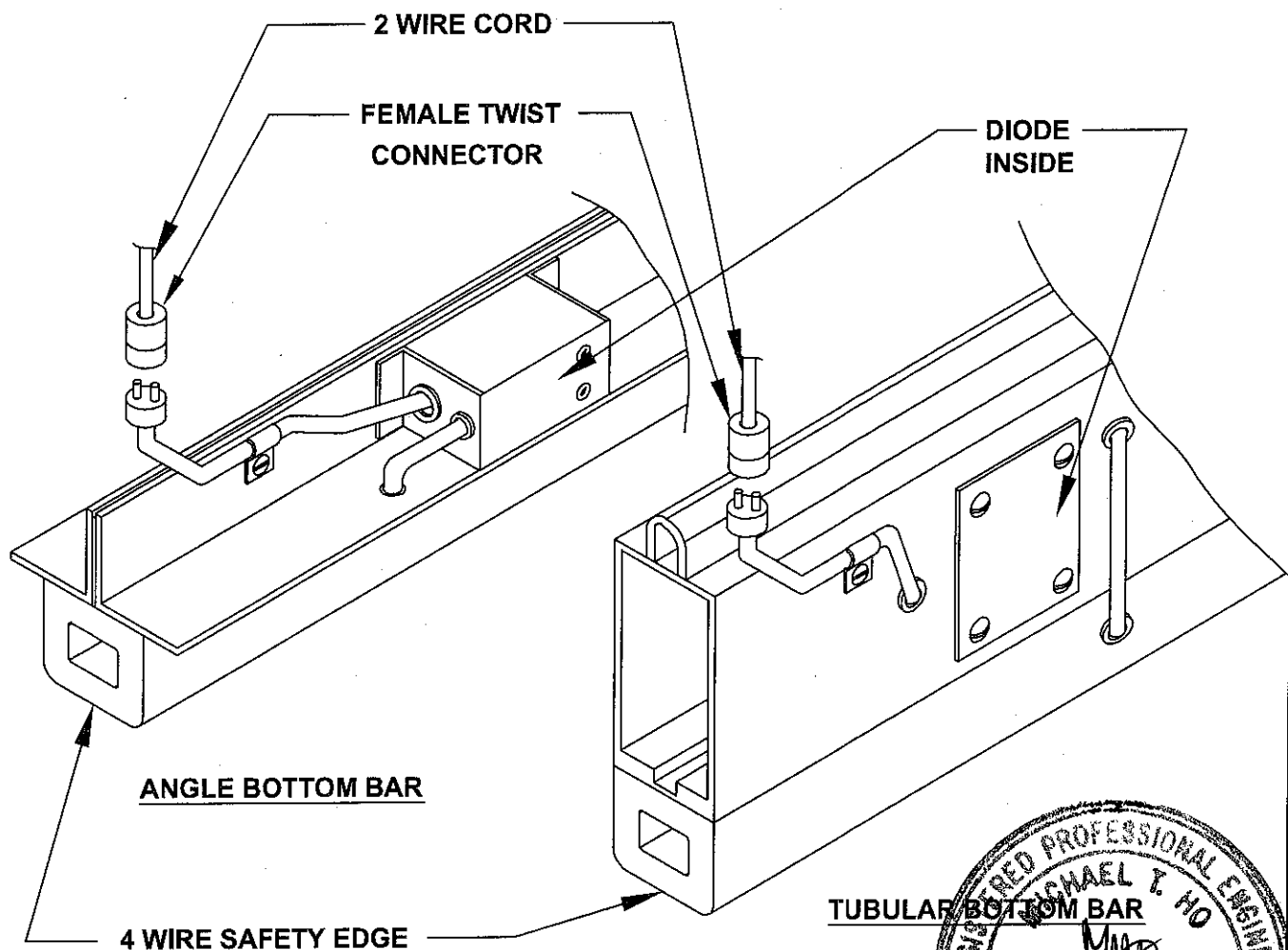
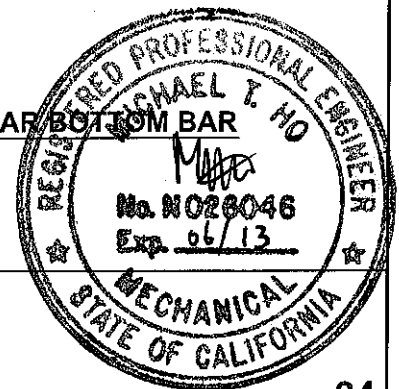

FIG 32



SETTING INSTRUCTIONS FOR FEATHEREDGE SWITCH

The Featheredge switch has been factory preset for normal operation from the supplier. The factory preset setting is 0.3mm to 0.4mm contact opening. Adjustment of the switch is not necessary unless operation will be under extremely unusual circumstances.

ALTERATION OF THE FACTORY PRESET SWITCH

- 1) Connect a multimeter/continuity tester (Ohm range) to the contact connectors on the switch.
- 2) Turn contact screw in a clockwise direction until contact is achieved.
(Contact opening = 0.0mm)
- 3) Turn the contact screw in a counter clockwise direction until the desired contact distance is reached. Scale division on the switch is: 1 Sub marking = 0.1mm of contact opening (Factory = 0.3mm to 0.4mm). The closer the setting is to 0.0mm, the more sensitive the switch becomes.

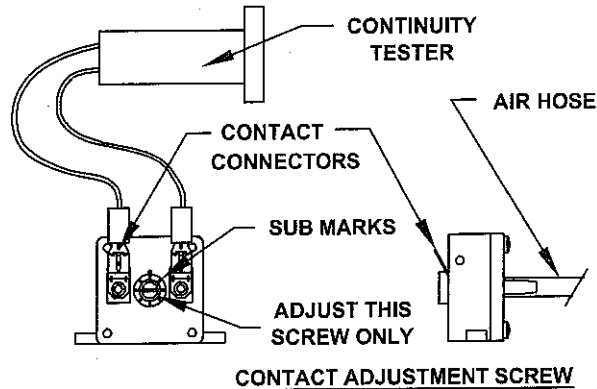

FIG 33

TOP SAFETY LIMIT SWITCH INSTALLATION

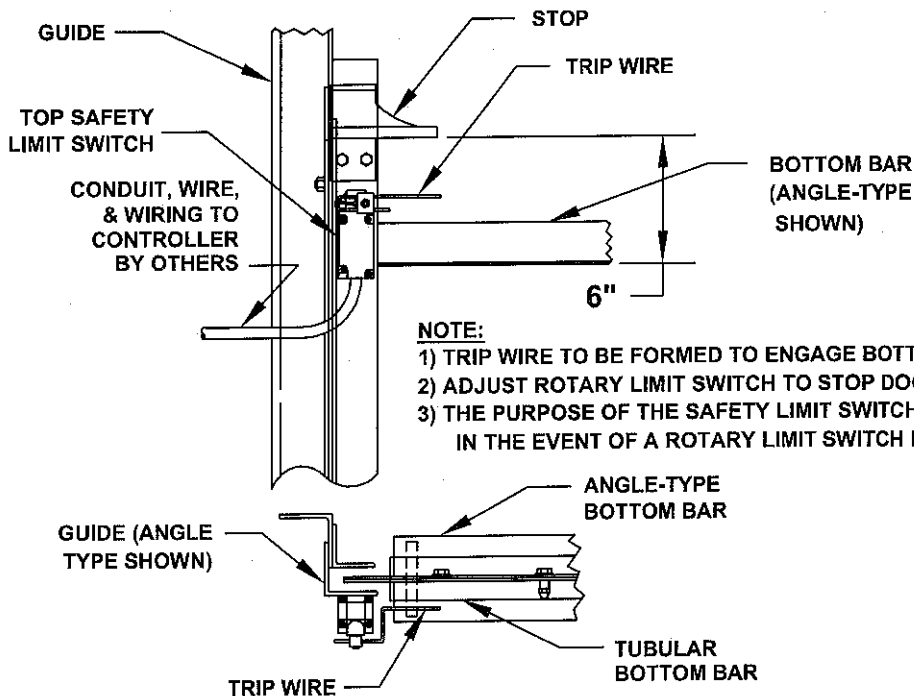
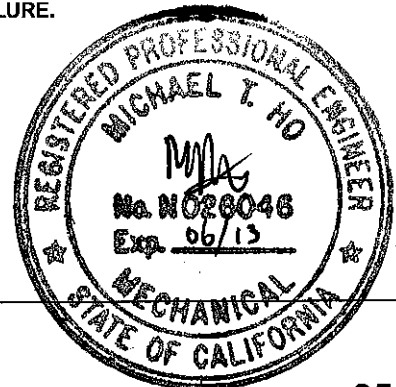
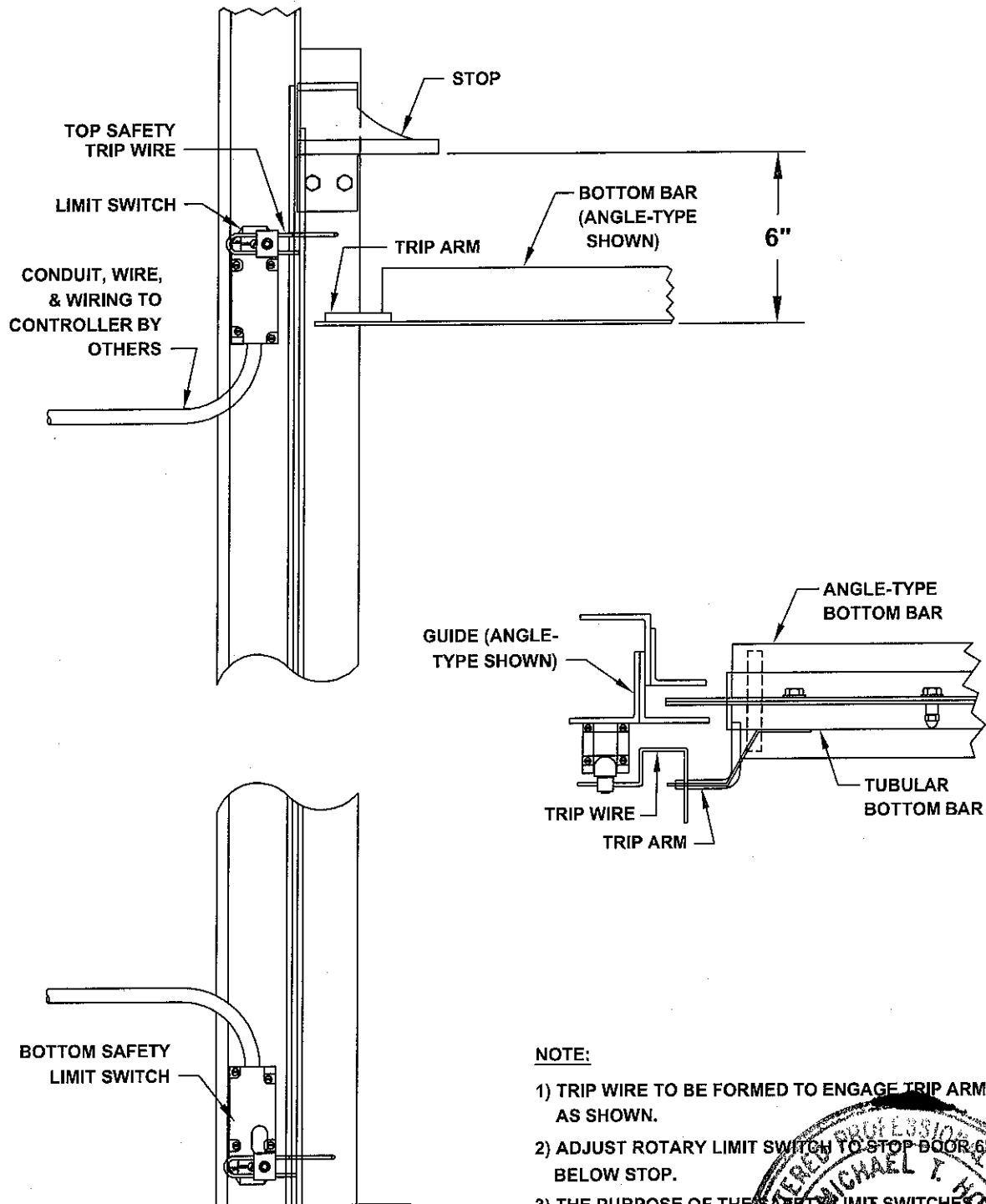

FIG 34



TOP AND BOTTOM SAFETY LIMIT SWITCH INSTALLATION



NOTE:

- 1) TRIP WIRE TO BE FORMED TO ENGAGE TRIP ARM AS SHOWN.
- 2) ADJUST ROTARY LIMIT SWITCH TO STOP DOOR 6" BELOW STOP.
- 3) THE PURPOSE OF THE SAFETY LIMIT SWITCHES ARE TO STOP THE DOOR IN THE EVENT OF ROTARY LIMIT SWITCH FAILURE.

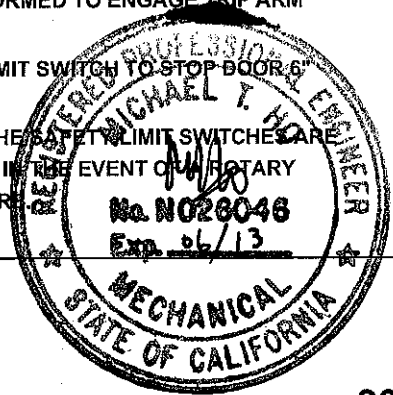

FIG 35

INERTIA BRAKE INSTALLATION INSTRUCTIONS

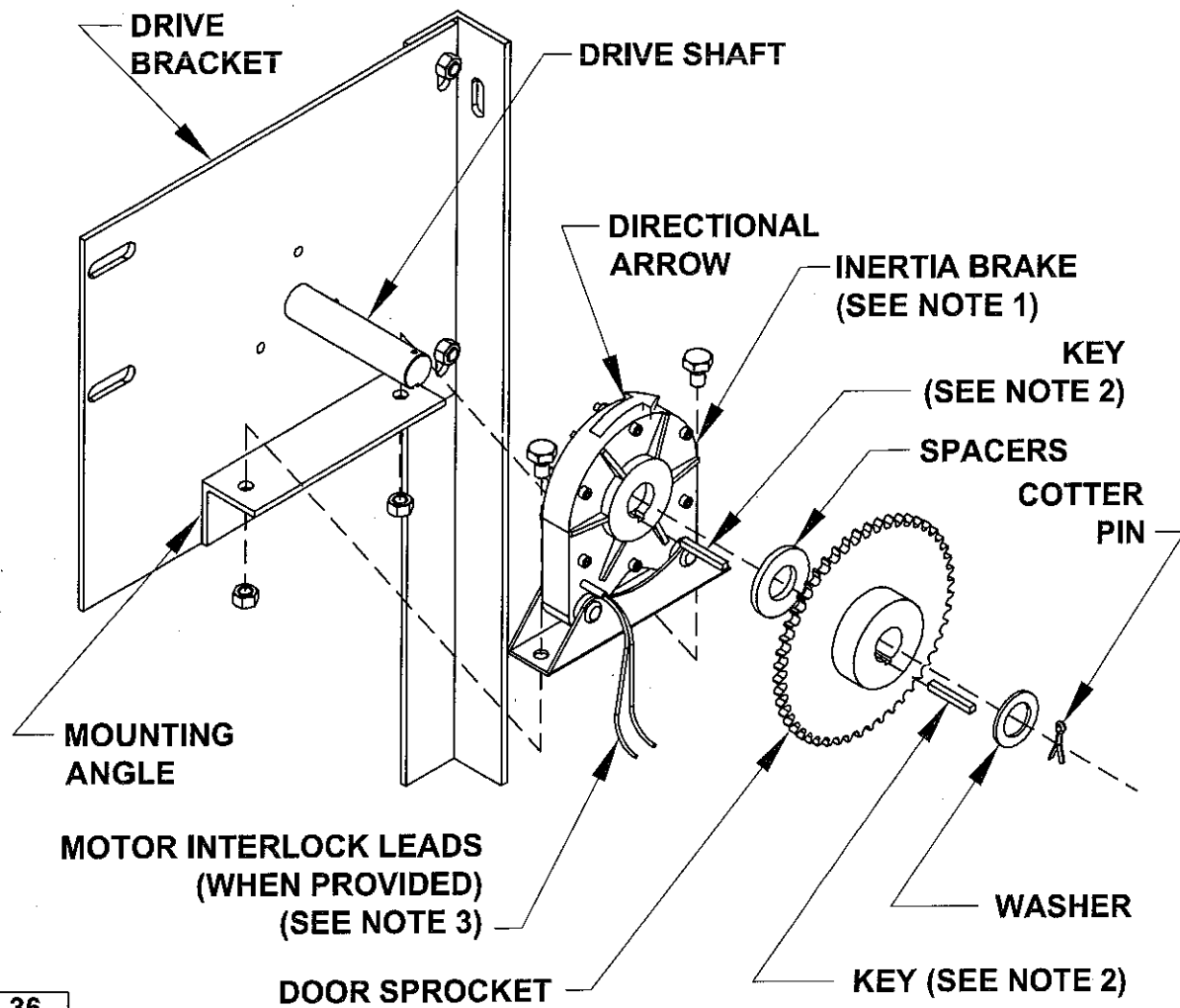

FIG 36

INSTRUCTIONS:

- 1) Remove Brake from Drive Bracket prior to mounting Barrel/Bracket Assy to Guides.
- 2) Slide Brake over end of Drive Shaft, align keyways and insert Key. **IMPORTANT:** Arrow on Brake must point in the direction the Barrel rotates when the door is closing.
- 3) Bolt Brake to Mounting Angle w/provided fasteners.
- 4) Install provided Spacers, Door Sprocket and Key as shown.
- 5) Align Sprocket with Motor Sprocket, tighten Sprocket Set Screws and install Washer & Cotter Pin to end of Drive Shaft.

NOTES:

- 1) Directional arrow on Brake must point in the direction the Barrel rotates when the Door is closing. (Towards the wall)
- 2) Key length must be at least as long as Hub.
- 3) Wire Interlock to Motor Control Circuit.

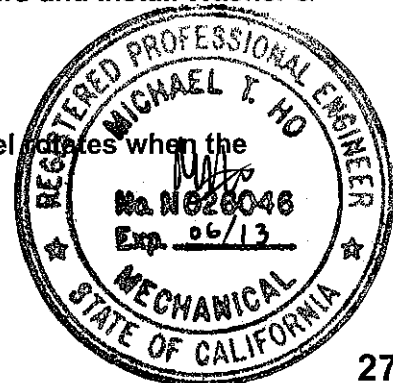

SERVICE DOOR GUIDE WEATHERSTRIP INSTALLATION INSTRUCTIONS

- 1) THIS DOOR(S) IS EQUIPPED WITH GUIDE WEATHERSTRIPPING, WHICH IS SHIPPED LOOSE AND PACKAGED WITH THE HOOD OR IN A SEPARATE TUBE. THE WEATHERSTRIPPING CONSISTS OF A PLASTIC EXTRUSION WITH A VINYL FLAP. IT IS DESIGNED TO BE INSTALLED WHEN THE DOOR(S) IS INSTALLED.
- 2) PRIOR TO INSTALLATION OF THE WEATHERSTRIP, MEASURE THE GUIDE'S CURTAIN SLOT THROUGH THEIR FULL HEIGHT. THESE SLOTS ARE FACTORY PRESET, BUT MIGHT BE ALTERED BY JARRING DURING SHIPMENT OR INSTALLATION. COMPARE THE MEASUREMENTS TO THE ILLUSTRATIONS BELOW. TO OPEN A TIGHT SLOT, LOOSEN THE GUIDE BOLTS AND MOVE THE GUIDE ANGLES UNTIL THE PROPER SLOT DIMENSION IS OBTAINED AND RETIGHTEN THE BOLTS.

NOTICE: A RUBBER MALLET SHOULD BE USED TO PROPERLY INSTALL THE WEATHERSTRIP. DO NOT INSTALL THE WEATHERSTRIP USING A STEEL HAMMER. USE CAUTION WHEN INSTALLING THE WEATHERSTRIP BELOW FREEZING TEMPERATURES, AS IT MAY CRACK IF HANDLED OR INSTALLED IMPROPERLY. IF POSSIBLE STORE THE WEATHERSTRIP ABOVE FREEZING TEMPERATURES UNTIL INSTALL.

- 3) THE WEATHERSTRIP SHOULD COVER FROM THE BOTTOM OF THE BRACKET TO THE BOTTOM OF THE GUIDE. CHECK THIS BY EITHER MEASURING IT OR HOLDING IT UP TO THE GUIDE. IF THE WEATHERSTRIP DOES NOT COVER FROM THE GROUND TO THE BOTTOM OF THE BRACKET, A SPLICED SECTION IS NEEDED. PROCEED TO STEP 6. IF NO SPLICE IS NEEDED PROCEED TO STEP 4.
- 4) START AT THE TOP OF THE GUIDE AND WORK DOWNWARD. BE SURE THAT THE WEATHERSTRIP IS FULLY SEATED ON THE ANGLE. **NOTE:** STARTING AT THE BOTTOM MAY BE DIFFICULT, AS THE FLEXIBILITY OF THE MATERIAL WILL CAUSE IT TO PULL AWAY FROM THE GUIDE AS IT IS BEING INSTALLED.
- 5) RUN THE DOOR UP AND DOWN A FEW TIMES TO ENSURE THAT THE WEATHERSTRIP IS INSTALLED PROPERLY.

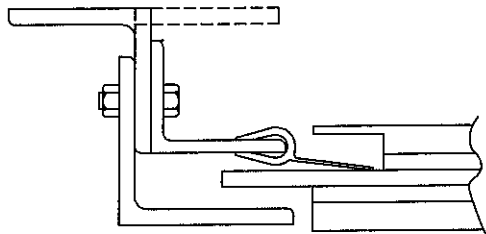
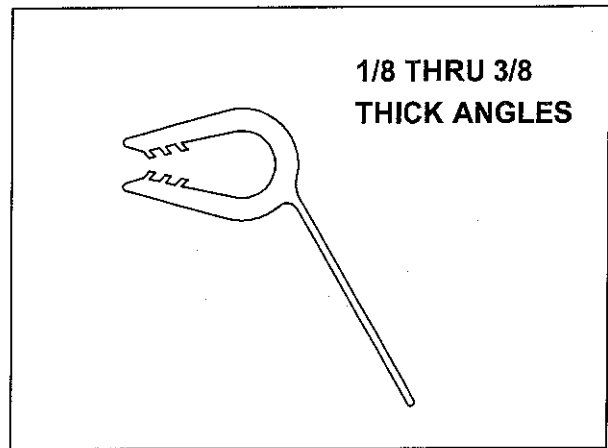
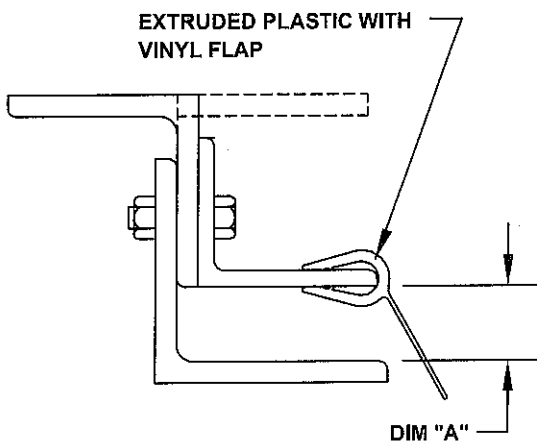

WEATHERSTRIP WITH TUBULAR BOTTOM BAR

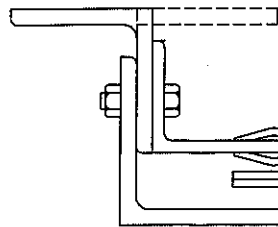

WEATHERSTRIP WITH ANGLE BOTTOM BAR

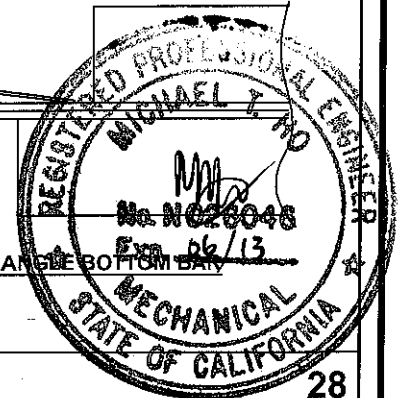

FIG 37

SERVICE DOOR GUIDE WEATHERSTRIP INSTALLATION INSTRUCTIONS (CONT)

NOTICE: A RUBBER Mallet SHOULD BE USED TO PROPERLY INSTALL THE WEATHERSTRIP. **DO NOT** INSTALL THE WEATHERSTRIP USING A STEEL HAMMER. USE CAUTION WHEN INSTALLING THE WEATHERSTRIP BELOW FREEZING TEMPERATURES, AS IT MAY CRACK IF HANDLED OR INSTALLED IMPROPERLY. IF POSSIBLE STORE THE WEATHERSTRIP ABOVE FREEZING TEMPERATURES UNTIL INSTALL.

- 6) A CRAFTSMAN HANDI-CUT UTILITY CUTTER IS RECOMMENDED (OR TIN SNIPS OR OTHER CUTTING DEVICE) FOR CUTTING THE WEATHERSTRIP. TRIM THE BOTTOM OF THE UPPER PIECE AT A 45 DEGREE ANGLE FROM THE CHANNEL THROUGH TO THE WIPER. TRIM THE TOP OF THE LOWER PIECE AT A 45 DEGREE ANGLE FROM THE WIPER AND CHANNEL. SEE FIGURE 38 FOR HOW TO TRIM THE WEATHERSTRIP. TAPE OR OTHER ADHESIVE CAN BE USED TO JOIN THE SPLICED WEATHERSTRIP, IF DESIRED.

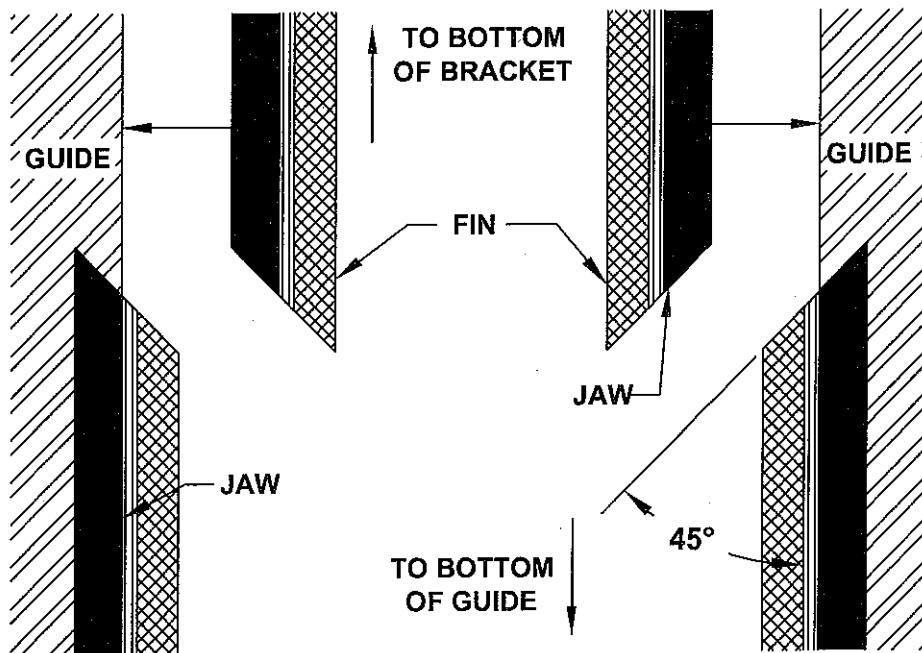
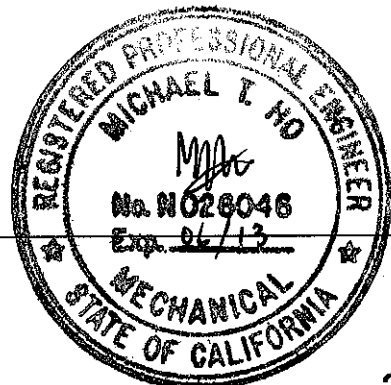
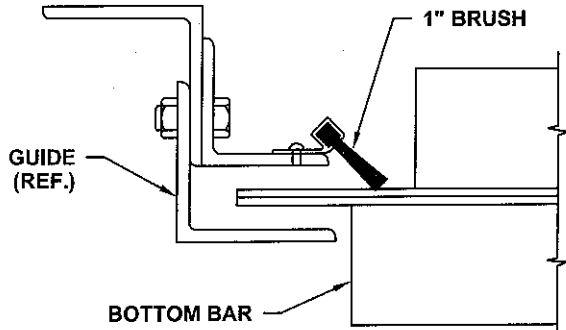

FIG 38



BRUSH TYPE GASKETING INSTALLATION INSTRUCTION



JAMB GASKET
(SHIP MOUNTED ON GUIDES)

FIG 39

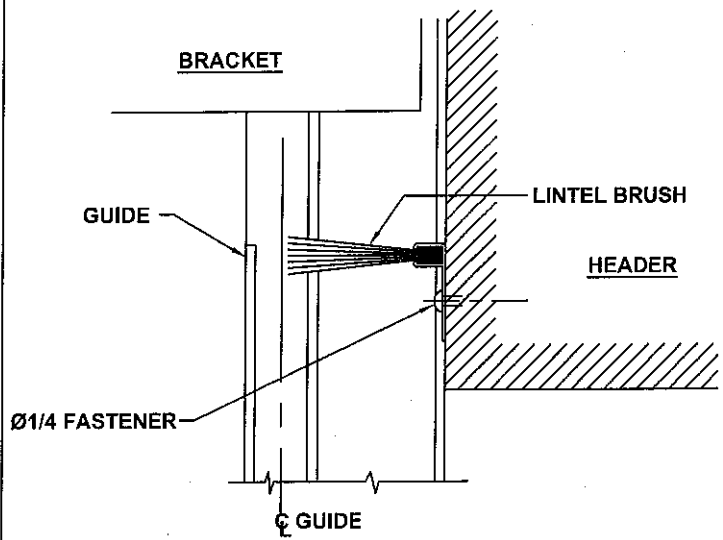

LINTEL GASKET

FIG 40

REVERSE HOOD BAFFLE INSTALLATION INSTRUCTION

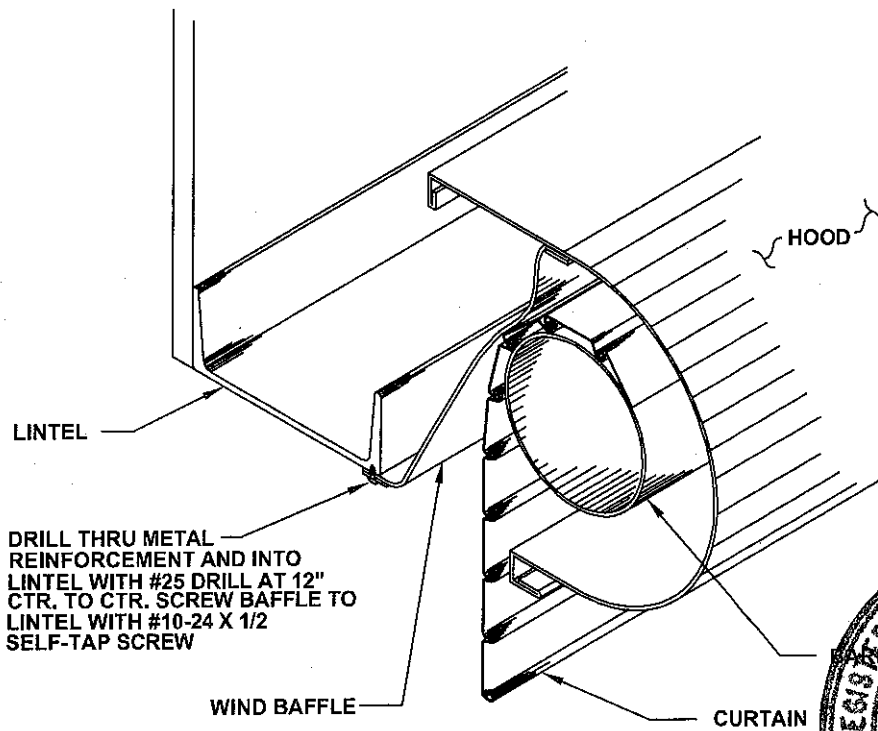
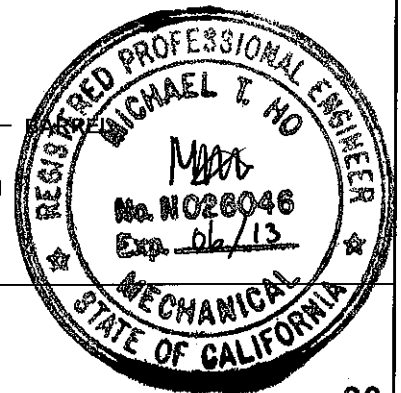

FIG 41



FLORIDA APPROVED DOORS

FASTENER TABLE

TYPE OF CONSTRUCTION TO WHICH FASTENER EMBEDS	TYPE OF FASTENER TO USE	MINIMUM EMBEDMENT	HOLE SIZE (DRILL Ø)	TAP SIZE (IF REQD)
CONCRETE 3000/4000 PSI	Ø1/2" X 4-1/2" HILTI KWIK BOLT 3 **	3-1/2"	---	---
	Ø3/4" X 5-1/2" HILTI KWIK BOLT 3 **	4-3/4"	---	---
STEEL	Ø1/2" BOLT	---	Ø27/64"	1/2-13 UNC
	Ø5/8 BOLT	---	Ø17/32"	5/8-11 UNC
	Ø3/4 BOLT	---	Ø21/32"	3/4-10 UNC

**ANCHORS TO BE INSTALLED PER MANUFACTURERS INSTRUCTIONS

OPTIONAL WELDED WALL ANGLE INSTALLATION

TYPE "A" DOORS

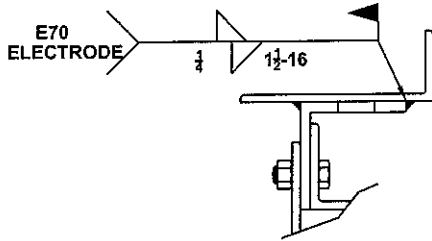

WELDING TO STEEL JAMB
(FOR TYPE 2 GUIDE ONLY)

FILLET WELD IN SLOT
100% OF PERIMETER
OF SLOT - 16" O.C. MAX
E70 ELECTRODE

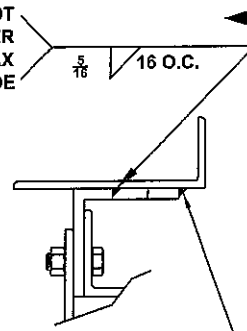

BETWEEN SLOTS
16" O.C. MAX
E70 ELECTRODE

ALTERNATE WELDING TO STEEL JAMB

TYPE "B" DOORS

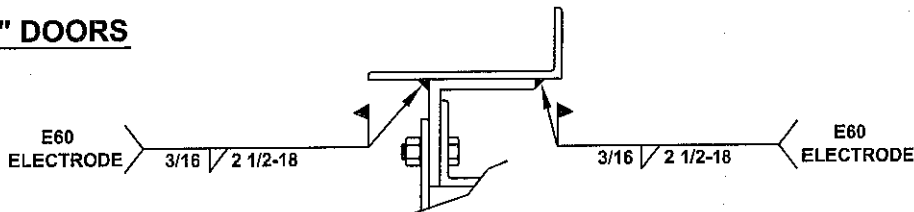

WELDING TO STEEL JAMB
(FOR TYPE 2 GUIDE ONLY)

TYPE "C" DOORS

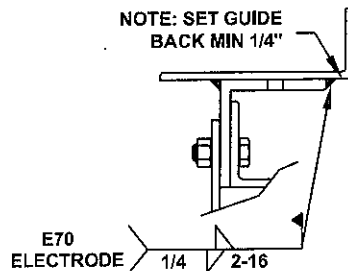

WELDING TO STEEL JAMB
(FOR TYPE 2 GUIDE ONLY)

